

Reductores sinfín/corona

Gearboxes *Worm Gearboxes*

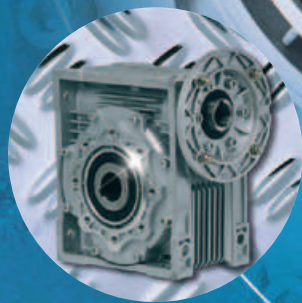
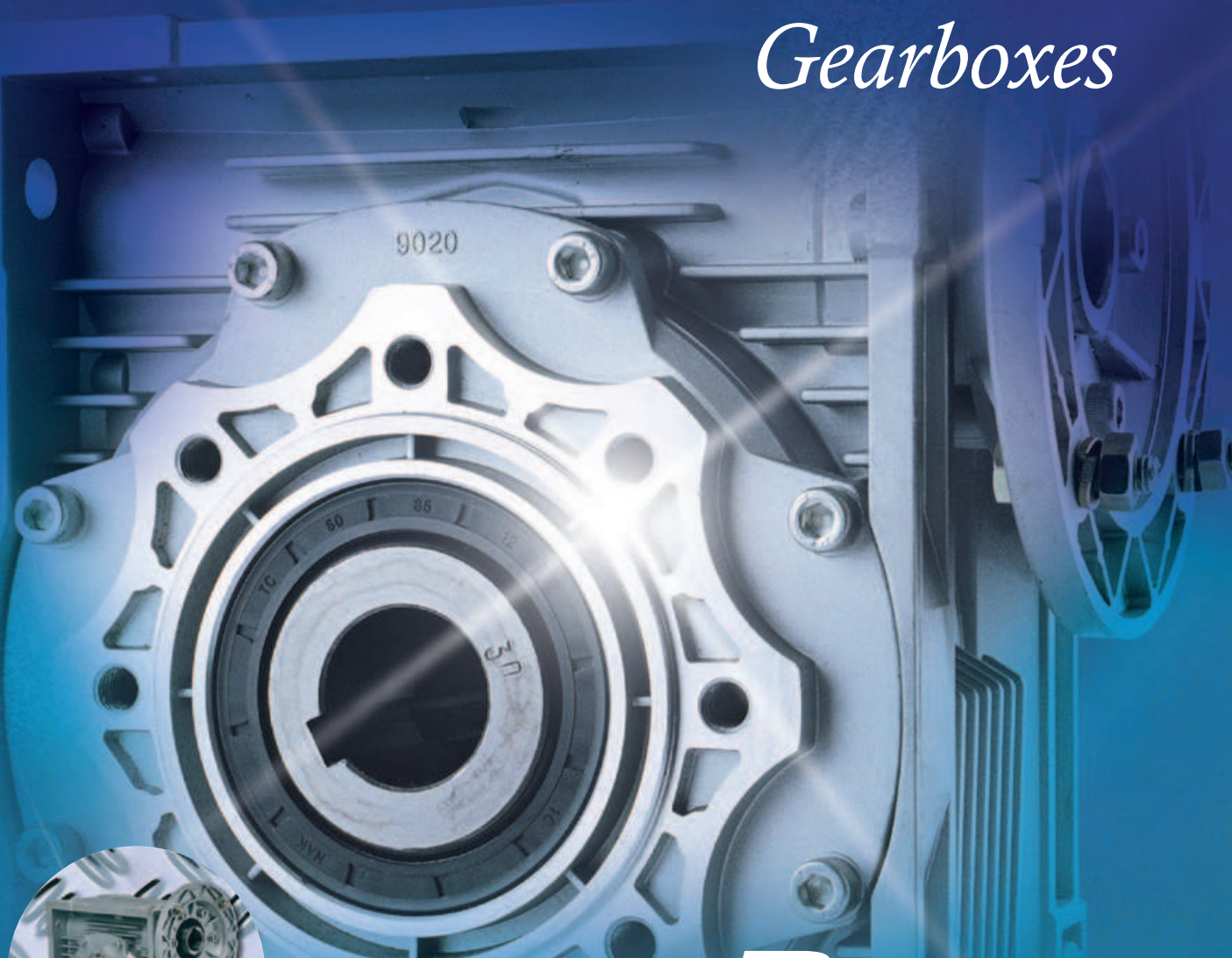

**BROWN
ADVANCE**

Máxima Competitividad Máxima Competitividad Experiencia, Servicio Servicio



◀ Reductor planetario con pares de salida desde 70 hasta 21 500 daNm.

Reductor coaxial con relaciones ▶ desde 1/3 hasta 1/280.

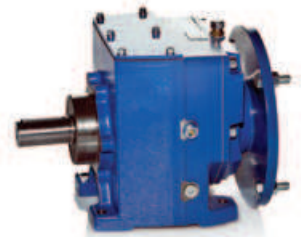

Reductor de ejes paralelos y ortogonales. ▼



Reductor sinfín/corona en tamaños BWQ30 a BWQ150. ▼

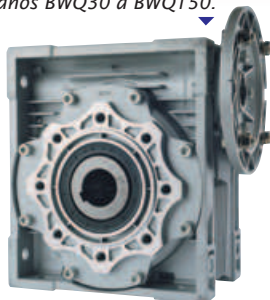

Variador de velocidad, ▶ para potencias desde 0,12Kw hasta 4Kw.



ÍNDICE / CONTENTS



Ejecuciones y características
Mounting facility and characteristics..... 4-8

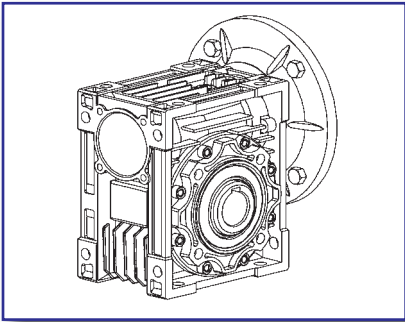

Reductor sinfín/corona BWQ
BWQ worm gearbox 9-23

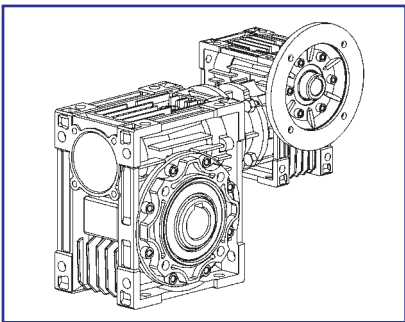

Reductor sinfín/corona combinado BWQ + BWQ
BWQ + BWQ combination worm gearbox.....24-28

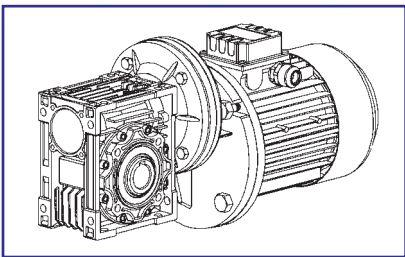

Reductor sinfín/corona con prerreducción BWQ + BH
BWQ + BH worm gearbox with pre-stage helical unit.....29-34

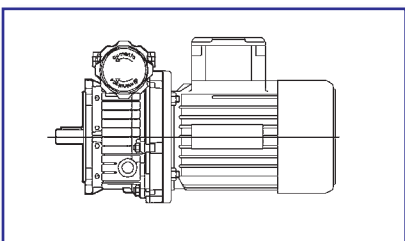

Motovariadores BV
BV motorvariators35-41

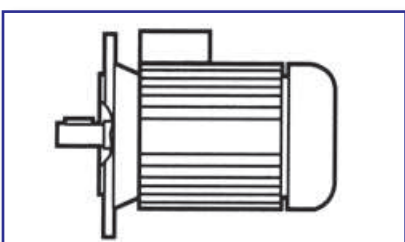

Dimensiones motores eléctricos
Electric motor dimensions 42

POSICIÓN DE MONTAJE / MOUNTING POSITION

BWQ			
B3	B6	V5	V6
	B7		
		BWQ + BH	
B3	B6	V5	V6
	B7		
		BWQ + BWQ	
A2	A1	A3	A4
A5	A6	A7	A8

POSICIÓN BRIDA DE SALIDA / OUTPUT FLANGE POSITION

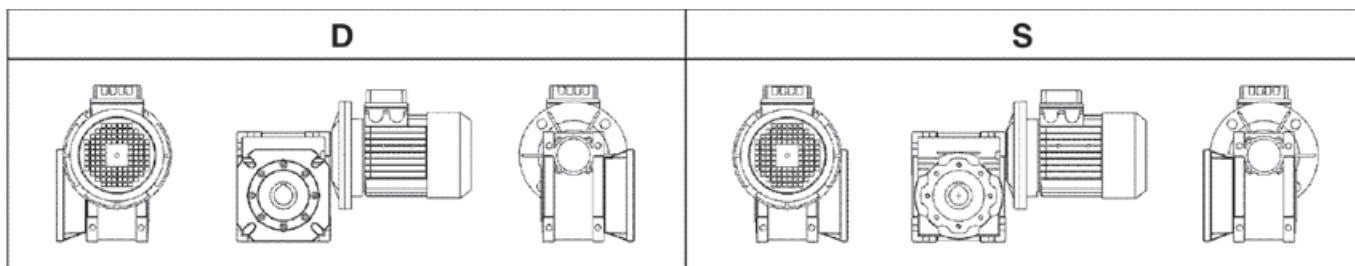

Si no se indica lo contrario, el reductor es entregado con brida en posición D en relación a posición B3.

Unless otherwise specified, gear reducers are supplied with flange in position D.

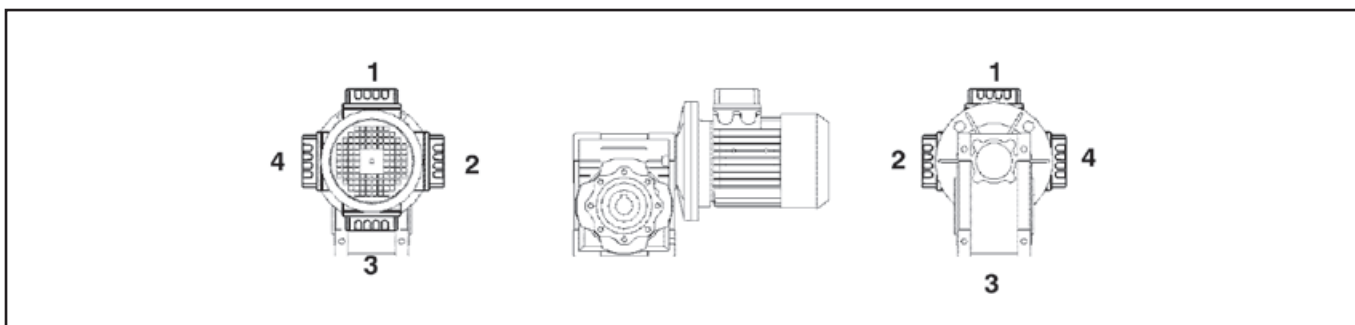

Si no se indica lo contrario, la caja de bornes del motor se monta en posición 1.

Unless otherwise specified, terminal box is supplied in position 1.

LUBRICACIÓN / LUBRICATION

Selección de servicio estándar
Factor Mínimo 1.0

Standard Selection Service
Minimum Factor 1.0

BWQ PESO SIN MOTOR
BWQ WEIGHTS WITHOUT MOTOR

Tipo / Type (Kgs)

BWQ30	1.2
BWQ40	2.3
BWQ50	3.5
BWQ63	6.2
BWQ75	9.0
BWQ90	13
BWQ110	35
BWQ130	48
BWQ150	84

Cantidad de aceite en litros.
Quantity of oil in litres.

Los reductores de los tamaños BWQ30, BWQ40, BWQ50, BWQ63, BWQ75 y BWQ90 son entregados con lubricante a vida, es decir aceite sintético AGIP TELIUM BSF y por lo tanto pueden ser montados en todas las posiciones de montaje previstas en el catálogo, a excepción de los tamaños BWQ75 y BWQ90 en la pos. V5 / V6 para lo cual es necesario ponerse en contacto con nuestro Servicio Técnico para evaluar las condiciones de empleo. Los reductores de los tamaños BWQ110-130 son entregados con lubricante, es decir aceite mineral AGIP BLASIA 460.

The reduction units size BWQ30, BWQ40, BWQ50, BWQ63, BWQ75 & BWQ90 are supplied complete with synthetic oil and lubricated for life. They can, therefore, be mounted in any position. The only exceptions are size BWQ75 and BWQ90 in pos V5 / V6 for which you should call our Technical Department to assess the conditions of use. The reduction units size BWQ110-130 are supplied complete with mineral oil lubricant.

BWQ	30	40	50	63	75	90	110	130	150
B3							3	4.5	7
B8	0.04	0.08	0.15	0.03	0.55	1	2.2	3.3	5.1
B6 - B7							2.5	3.5	5.4
V5 / V6							3	4.5	7

DENTADO Y RENDIMIENTO BWQ / WORM WHEEL TOOTH AND EFFICIENCY BWQ

BWQ	i	7,5	10	15	20	25	30	40	50	60	80	100
25	Z1	4	3	2	2		1	1	1	1		
	Y	25° 18'	19° 31'	13° 18'	10° 53'		6° 44'	5° 29'	4° 34'	3° 56'		
	mx	1,3	1,3	1,3	1		1,3	1	0,8	0,67		
	hd	0,84	0,82	0,78	0,74		0,66	0,61	0,57	0,54		
	hs	0,7	0,67	0,6	0,55		0,46	0,41	0,36	0,34		
30	Z1	4	3	2	2	1	1	1	1	1	1	
	Y	18° 50'	14° 21'	9° 40'	7° 44'	5° 34'	4° 42'	3° 53'	3° 11'	2° 46'	2° 46'	
	mx	1,44	1,44	1,44	1,1	1,7	1,44	1,1	0,88	0,75	0,56	
	hd	0,84	0,81	0,76	0,72	0,67	0,64	0,58	0,54	0,5	0,44	
	hs	0,66	0,62	0,54	0,5	0,43	0,39	0,35	0,31	0,27	0,23	
40	Z1	4	4	2	2	2	1	1	1	1	1	1
	Y	21° 48'	17° 31'	11° 18'	8° 58'	7° 41'	5° 42'	4° 30'	3° 51'	3° 17'	2° 32'	2° 05'
	mx	2	1,5	2	1,5	1,25	2	1,5	1,25	1,04	0,78	0,63
	hd	0,86	0,85	0,81	0,77	0,74	0,69	0,64	0,61	0,57	0,51	0,47
	hs	0,69	0,65	0,58	0,53	0,5	0,44	0,4	0,36	0,32	0,28	0,24
50	Z1	4	4	2	2	2	1	1	1	1	1	1
	Y	21° 48'	17° 42'	11° 18'	9° 04'	7° 36'	5° 42'	4° 32'	3° 49'	3° 17'	2° 33'	2° 04'
	mx	2,5	1,9	2,5	1,9	1,54	2,5	1,9	1,54	1,3	0,98	0,78
	hd	0,86	0,84	0,8	0,77	0,74	0,7	0,65	0,61	0,57	0,51	0,49
	hs	0,69	0,65	0,58	0,54	0,5	0,44	0,39	0,35	0,32	0,27	0,23
63	Z1	4	4	2	2	2	1	1	1	1	1	1
	Y	24° 31'	20° 19'	12° 50'	10° 29'	8° 44'	6° 30'	5° 17'	4° 23'	3° 47'	2° 59'	2° 25'
	mx	3,25	2,5	3,25	2,5	2	3,25	2,5	2	1,68	1,28	1,02
	hd	0,87	0,86	0,82	0,8	0,77	0,73	0,69	0,65	0,61	0,56	0,5
	hs	0,7	0,65	0,59	0,54	0,5	0,45	0,4	0,36	0,33	0,28	0,24
75	Z1	4	4	2	2	2	1	1	1	1	1	1
	Y	26° 33'	21° 48'	14° 02'	11° 18'	9° 37'	7° 07'	5° 42'	4° 50'	4° 05'	3° 15'	2° 40'
	mx	4	3	4	3	2,45	4	3	2,45	2	1,54	1,24
	hd	0,88	0,87	0,84	0,81	0,79	0,75	0,71	0,68	0,64	0,59	0,54
	hs	0,7	0,67	0,6	0,57	0,52	0,46	0,42	0,38	0,35	0,29	0,26
90	Z1	4	4	2	2	2	1	1	1	1	1	1
	Y	28° 20'	23° 26'	15° 05'	12° 14'	10° 37'	7° 40'	6° 11'	5° 21'	4° 36'	3° 36'	2° 57'
	mx	4,8	3,6	4,8	3,6	3	4,8	3,6	3	2,5	1,88	1,5
	hd	0,89	0,88	0,85	0,83	0,81	0,77	0,74	0,71	0,68	0,62	0,58
	hs	0,72	0,69	0,63	0,59	0,55	0,49	0,45	0,41	0,38	0,32	0,28
110	Z1	4	4	2	2	2	1	1	1	1	1	1
	Y	28° 17'	27° 35'	15° 03'	14° 38'	12° 37'	7° 39'	7° 26'	6° 23'	5° 31'	4° 23'	3° 38'
	mx	5,89	4,6	5,89	4,6	3,75	5,89	4,6	3,75	3,12	2,36	1,9
	hd	0,89	0,88	0,85	0,84	0,83	0,78	0,77	0,74	0,71	0,66	0,62
	hs	0,71	0,68	0,62	0,61	0,58	0,48	0,48	0,44	0,41	0,36	0,32
130	Z1	4	4	2	2	2	1	1	1	1	1	1
	Y	28° 46'	26° 15'	15° 21'	13° 51'	11° 49'	7° 48'	7° 01'	5° 58'	5° 12'	4° 05'	3° 25'
	mx	7	5,4	7	5,4	4,37	7	5,4	4,37	3,68	2,75	2,24
	hd	0,9	0,88	0,86	0,85	0,83	0,79	0,77	0,74	0,71	0,67	0,63
	hs	0,71	0,68	0,62	0,6	0,57	0,49	0,46	0,43	0,39	0,34	0,3
150	Z1	6	4	3	2	2	2	1	1	1	1	1
	Y	32° 09'	24° 35'	17° 27'	12° 53'	11° 19'	9° 50'	6° 32'	5° 43'	4° 57'	3° 55'	3° 14'
	mx	5,5	6,155	5,58	6,155	5	4,193	6,155	5	4,193	3,17	2,55
	hd	0,91	0,9	0,88	0,86	0,84	0,83	0,78	0,76	0,73	0,68	0,64
	hs	0,73	0,71	0,66	0,6	0,57	0,54	0,45	0,42	0,39	0,33	0,29

Hélice con sentido derecha / *The helix is right-handed.*

Y = Ángulo de la hélice / *Helix angle*
 mx = Módulo / *Module*

hd = Rendimiento dinámico / *Dynamic efficiency*
 hs = Rendimiento estático / *Static efficiency*

PRESTACIONES BWQ / PERFORMANCE BWQ

i	n2	n1 = 2800									
			30	40	50	63	75	90	110	130	150
7,5	373	kw1	0,58	1,23	2,26	4,04	5,58	8,92	14,50	22,10	35,7
		M2	13	28	52	93	130	210	340	520	840
10	280	kw1	0,45	0,97	1,80	3,20	4,72	7,60	12,20	18,70	28,4
		M2	13	29	54	97	145	235	380	580	890
15	187	kw1	0,31	0,72	1,31	2,34	3,37	6	9,3	14,7	19,8
		M2	13	31	57	103	150	270	425	670	910
20	140	kw1	0,23	0,52	0,95	1,75	2,76	4,4	7	11	16,1
		M2	12	29	53	100	170	260	420	660	980
25	112	kw1	0,25	0,42	0,75	1,32	2,12	3,5	5,9	9	12
		M2	16	28	51	92	150	250	440	670	890
30	93	kw1	0,21	0,44	0,82	1,5	2,1	3,7	5,7	9	10,5
		M2	15	34	64	120	170	310	480	770	920
40	70	kw1	0,16	0,32	0,59	1,06	1,57	2,5	4,1	6,5	10,6
		M2	14	31	59	108	165	275	460	730	1200
50	56	kw1	0,12	0,26	0,45	0,83	1,2	2	3,3	5,1	8,1
		M2	13	30	53	100	150	265	450	700	1100
60	47	kw1	0,1	0,21	0,37	0,68	1	1,62	2,73	4	6,2
		M2	12	28	50	95	145	245	430	640	990
80	35	kw1	0,08	0,16	0,27	0,49	0,72	1,2	1,9	3	4,6
		M2	11	25	45	85	130	225	380	590	920
100	28	kw1		0,12	0,21	0,37	0,58	0,9	1,49	2,18	3,3
		M2		23	40	74	120	200	350	520	810

i	n2	n1 = 1400									
			30	40	50	63	75	90	110	130	150
7,5	187	kw1	0,41	0,9	1,58	2,84	4,1	6,3	10,4	16,1	25,8
		M2	18	40	71	128	185	290	480	750	1200
10	140	kw1	0,32	0,69	1,23	2,19	3,25	5,1	8,57	13,5	20,2
		M2	18	40	72	130	195	310	520	820	1240
15	93	kw1	0,23	0,48	0,88	1,65	2,3	4,1	6,5	10,3	13,9
		M2	18	40	74	140	200	360	570	920	1250
20	70	kw1	0,18	0,37	0,68	1,22	1,88	3,1	4,8	7,8	11,1
		M2	18	39	73	135	210	355	560	910	1300
25	56	kw1	0,18	0,3	0,54	0,98	1,47	2,43	4,1	6,5	8,4
		M2	21	38	70	130	200	340	590	930	1200
30	47	kw1	0,15	0,31	0,57	1,1	1,48	2,6	3,9	6,35	7,1
		M2	20	45	84	160	230	410	630	1040	1200
40	35	kw1	0,11	0,23	0,42	0,76	1,12	1,76	2,9	4,9	7,3
		M2	18	41	76	145	220	360	610	1050	1550
50	28	kw1	0,09	0,18	0,34	0,6	0,89	1,38	2,4	3,8	5,4
		M2	17	39	73	135	210	340	600	980	1400
60	23	kw1	0,08	0,15	0,28	0,51	0,75	1,13	1,9	3	4,2
		M2	16	36	68	130	200	320	560	900	1260
80	18	kw1	0,05	0,12	0,22	0,39	0,58	0,83	1,3	2,3	3,1
		M2	13	33	65	122	190	285	490	840	1150
100	14	kw1		0,09	0,16	0,34	0,48	0,67	1,1	1,7	2,3
		M2		29	55	118	180	270	460	740	1000

i	n2	n1 = 900									
			30	40	50	63	75	90	110	130	150
7,5	120	kw1	0,3	0,65	1,23	2,18	3,1	4,8	8	12,3	19,5
		M2	20	44	84	151	215	340	565	880	1400
10	90	kw1	0,24	0,5	0,94	1,7	2,52	4	6,6	10,3	15,7
		M2	20	44	84	153	230	370	620	960	1480
15	60	kw1	0,17	0,36	0,67	1,2	1,8	3,10	4,9	7,8	10,5
		M2	20	45	84	155	235	420	660	1060	1450
20	45	kw1	0,13	0,28	0,48	0,91	1,4	2,3	3,6	5,8	8,4
		M2	20	44	77	148	235	390	630	1040	1500
25	36	kw1	0,14	0,23	0,39	0,69	1,1	1,8	3,1	4,8	6,3
		M2	23	43	75	137	215	370	660	1050	1380
30	30	kw1	0,11	0,23	0,42	0,79	1,1	1,9	3	4,7	5,4
		M2	21	49	90	175	260	460	730	1170	1400
40	23	kw1	0,09	0,17	0,31	0,58	0,83	1,36	2,2	3,5	5,7
		M2	20	45	82	160	240	410	690	1100	1800
50	18	kw1	0,07	0,14	0,25	0,45	0,65	1,1	1,8	2,8	4,1
		M2	18	42	77	145	220	390	680	1050	1600
60	15	kw1	0,06	0,11	0,21	0,37	0,54	0,86	1,4	2,1	3,2
		M2	17	39	72	138	210	350	620	940	1440
80	11	kw1	0,04	0,09	0,16	0,29	0,43	0,63	1	1,6	2,4
		M2	15	35	68	128	200	315	540	860	1300
100	9	kw1		0,07	0,12	0,25	0,36	0,49	0,8	1,3	1,8
		M2		32	56	124	190	280	490	780	1150

i	n2	n1 = 500									
			30	40	50	63	75	90	110	130	150
7,5	120	kw1	0,21	0,45	0,86	1,51	2,14	3,3	5,50	8,6	13,5
		M2	24	54	103	184	260	410	690	1080	1700
10	90	kw1	0,16	0,4	0,67	1,18	1,7	2,7	4,6	7,1	10,7
		M2	24	54	103	185	270	435	740	1160	1780
15	60	kw1	0,12	0,26	0,47	0,85	1,2	2,1	3,4	5,5	7,2
		M2	24	55	103	187	280	490	790	1300	1730
20	45	kw1	0,09	0,19	0,33	0,63	0,98	1,6	2,5	4	5,9
		M2	23	52	93	178	285	470	750	1230	1820
25	36	kw1	0,1	0,15	0,28	0,48	0,73	1,23	2,1	3,2	4,3
		M2	29	49	91	164	255	440	790	1200	1630
30	30	kw1	0,08	0,16	0,29	0,54	0,77	1,4	2,1	3,4	3,8
		M2	26	58	108	200	300	550	870	1400	1670
40	23	kw1	0,06	0,12	0,22	0,4	0,58	1	1,5	2,4	3,9
		M2	23	53	98	185	280	480	810	1300	2120
50	18	kw1	0,05	0,1	0,17	0,32	0,44	0,75	1,3	1,9	2,9
		M2	21	49	91	173	250	450	800	1220	1870
60	15	kw1	0,04	0,08	0,14	0,26	0,37	0,6	1	1,5	2,3
		M2	19	46	83	160	240	400	710	1070	1680
80	11	kw1	0,03	0,06	0,11	0,19	0,29	0,5	0,7	1,1	1,7
		M2	17	40	75	137	215	365	60	970	1530
100	9	kw1		0,05	0,09	0,16	0,24	0,35	0,6	0,9	1,3
		M2		36	65	128	210	330	570	860	1350

A 2800 rpm la potencia indicada es mecánica. Para esta velocidad las relaciones entre 7,5 y 30 no deben utilizarse para trabajos continuos.

Power values for input speed at 2800 are mechanical valves, in the case of ratios from 7,5 to 30, they must not be adopted for continuous duty.

CARGAS SOBRE EL EJE / SHAFT LOADS

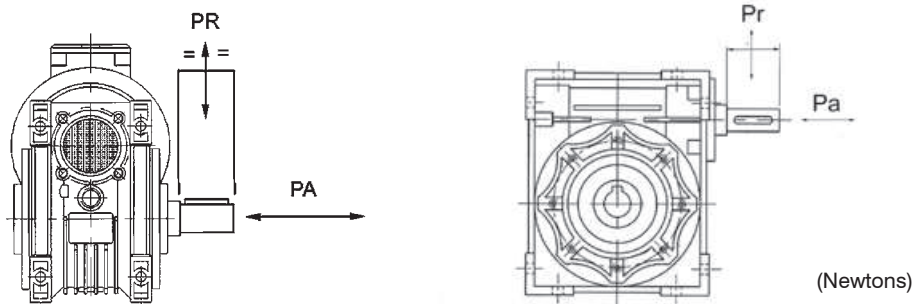

TYPE	I	7.5:1	10:1	15:1	20:1	25:1	30:1	40:1	50:1	60:1	80:1	100:1
		n1=1400	186	140	94	70	56	47	35	28	23	18
BWQ 30	PR	590	680	150	860	940	1000	1000	1100	1200	1400	----
	PA	190	200	215	237	250	250	270	287	287	350	----
	Pr	150	150	160	160	190	210	210	210	210	210	----
	Pa	20	20	20	20	20	20	20	20	20	20	----
BWQ 40	PR	1350	1450	1660	1850	1970	2100	2300	2500	2650	2900	3190
	PA	337	362	415	462	492	525	575	625	662	725	797
	Pr	380	380	380	380	380	380	380	380	380	380	380
	Pa	95	95	95	95	95	95	95	95	95	95	95
BWQ 50	PR	1810	1930	2280	2505	2696	2865	3160	3400	3620	4000	4290
	PA	452	482	570	626	674	716	790	850	905	1000	1072
	Pr	485	485	485	485	485	485	485	485	485	485	485
	Pa	121	121	121	121	121	121	121	121	121	121	121
BWQ 63	PR	2365	2600	2980	3285	3540	3760	4150	4460	4730	5200	5600
	PA	591	650	745	821	885	940	1037	1115	1182	1300	1400
	Pr	580	580	580	580	580	580	580	580	580	580	580
	Pa	145	145	145	145	145	145	145	145	145	145	145
BWQ 75	PR	2800	3100	3520	3900	4170	4450	4890	5260	5580	6150	6630
	PA	700	775	880	975	1042	1112	1222	1315	1395	1537	1657
	Pr	650	650	650	650	650	650	650	650	650	650	650
	Pa	163	163	163	163	163	163	163	163	163	163	163
BWQ 90	PR	3085	3400	3850	4300	4650	4900	5450	5850	6200	6820	7340
	PA	771	850	962	1075	1162	1225	1362	1462	1550	1705	1835
	Pr	850	850	850	850	850	850	850	850	850	850	850
	Pa	213	213	213	213	213	213	213	213	213	213	213
BWQ 110	PR	3900	4310	4950	5450	5880	6210	6830	7350	7795	8600	9300
	PA	975	1077	1237	1362	1470	1552	1707	1837	1948	2150	2325
	Pr	950	950	950	950	950	950	950	950	950	950	950
	Pa	238	238	238	238	238	238	238	238	238	238	238
BWQ 130	PR	5000	5600	6400	7000	7500	8000	8700	9500	10000	11000	12000
	PA	1225	1263	1400	1483	1713	1975	2200	2525	2525	2900	2900
	Pr	1500	1800	2000	2100	2100	2100	2100	2100	2100	2100	2100
	Pa	300	300	300	300	300	300	300	300	300	300	300
BWQ 150	PR	6962	7663	8871	9654	10400	11051	12163	13103	13924	16508	
	PA	1450	1472	1605	1690	1912	2143	2300	2510	2700	3000	
	Pr	1950	2267	2285	2674	2800	2800	2800	2800	2800	2800	
	Pa	340	340	340	340	340	340	340	340	340	340	

CARGAS RADIALES Y AXIALES

Las cifras indicadas en la tabla, corresponden a las cargas radiales y axiales a potencia máxima. Para cargas radiales y axiales combinadas rogamos consulte con nuestro departamento técnico. A bajas potencias, las cargas se pueden incrementar. Para poder obtener cifras exactas a una velocidad y potencia determinadas, rogamos consulten con nuestro departamento técnico.

CARCASA BWQ30 - BWQ90

Las carcasas y bridas se fabrican con aluminio de alta resistencia UNI 5076.

CARCASA BWQ110 y BWQ130

Las carcasas y bridas están fabricadas en fundición de hierro G25.

RADIAL & AXIAL SHAFT LOADS

The figures in the table indicate the permissible radial and axial loads at maximum power.

For combined radial and axial loads, please contact our technical department.

At lower powers the loads may be increased - for precise loading figures for each actual power and speed, please contact our technical department.

GEARCASE BWQ30 - BWQ90

The casing and flanges are made in high strength UNI 5076 aluminium.

GEARCASE BWQ110 - BWQ130

The casing and flanges are made in G25 cast iron.

Reductor y motorreductor
tipo sinfín/corona

*Worm gearbox and
geared motor*

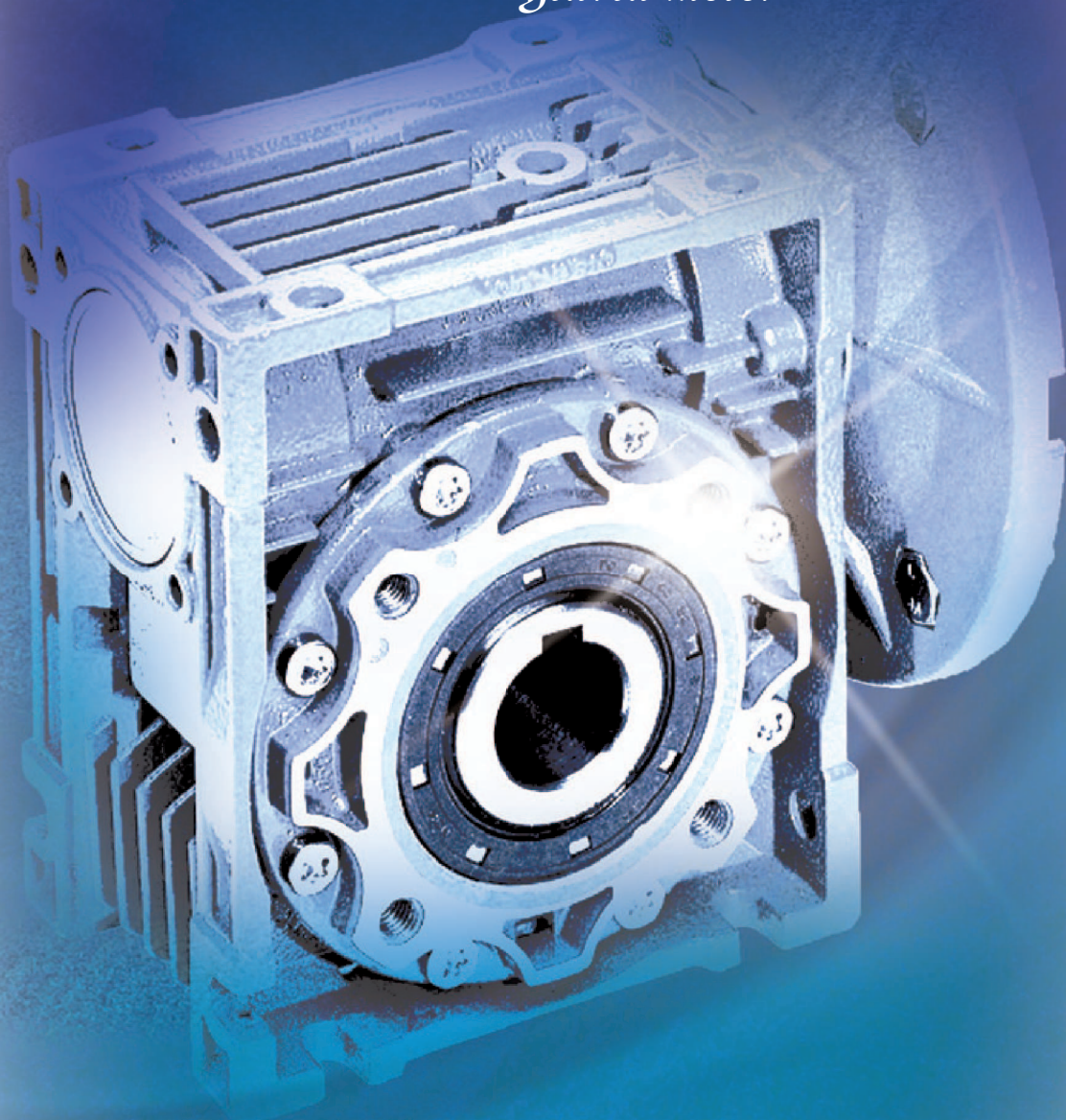

BWQ

SELECCIÓN / SELECTION

Type	n2	Ratio :1	Max kW	M2 nM	Max M2 nM	Eff %	Motor Frame Size (kW)																
							56	56	63	63	71	71	80	80	90	90	100	100	112				
BWQ 25	280	5:1	0,25	12	29	91	0.06	0.09															
	186	7.5:1	0,25	12	29	90	0.06	0.09															
	140	10:1	0,22	11	27	87	0.06	0.09															
	93	15:1	0,14	11	27	84	0.06	0.09															
	70	20:1	0,12	11	27	82	0.06	0.09															
	56	25:1	7,1	10	24	80	0.06	0.09															
	47	30:1	0,1	10	24	79	0.06	0.09															
	35	40:1	0,08	10	24	73	0.06	0.09															
	28	50:1	0,05	12	27	69	0.06	0.09															
	23	60:1	0,04	14	32	62	0.06	0.09															
BWQ 30	186	7.5:1	0.44	20	42	91	0.06	0.09	0.12	0.18													
	140	10:1	0.33	20	42	89	0.06	0.09	0.12	0.18													
	93	15:1	0.24	21	44	86	0.06	0.09	0.12	0.18													
	70	20:1	0.19	21	44	83	0.06	0.09	0.12	0.18													
	56	25:1	0.15	21	44	83	0.06	0.09	0.12	0.18													
	47	30:1	0.11	17	32	76	0.06	0.09	0.12														
	35	40:1	0.08	16	30	71	0.06	0.09															
	28	50:1	0.06	14	24	66	0.06																
	23	60:1	0.06	16	27	62	0.06																
	20	70:1	N/A																				
	18	80:1	0.04	13	21	55	0.06																
14	100:1	N/A																					
BWQ 40	186	7.5:1	1.20	55	135	92			0.12	0.18	0.25	0.37											
	140	10:1	0.88	56	136	89			0.12	0.18	0.25	0.37											
	93	15:1	0.65	59	144	85			0.12	0.18	0.25	0.37											
	70	20:1	0.49	59	143	84			0.12	0.18	0.25	0.37											
	56	25:1	0.44	61	149	78			0.12	0.18	0.25	0.37											
	47	30:1	0.38	61	149	75			0.12	0.18	0.25	0.37											
	35	40:1	0.26	55	134	74		0.09	0.12	0.18	0.25												
	28	50:1	0.20	52	127	73		0.09	0.12	0.18													
	23	60:1	0.16	45	101	66		0.09	0.12	0.18													
	20	70:1	N/A																				
	18	80:1	0.12	39	88	57	0.06	0.09	0.12														
14	100:1	0.10	38	85	53	0.06	0.09	0.12															
BWQ 50	186	7.5:1	1.75	80	196	92					0.25	0.37	0.55	0.75									
	140	10:1	1.25	80	196	90					0.25	0.37	0.55	0.75									
	93	15:1	0.90	84	207	88					0.25	0.37	0.55	0.75									
	70	20:1	0.80	98	240	86					0.25	0.37	0.55	0.75									
	56	25:1	0.75	105	258	79					0.25	0.37	0.55	0.75									
	47	30:1	0.62	101	246	76					0.25	0.37	0.55	0.75									
	35	40:1	0.44	94	230	75			0.12	0.18	0.25	0.37											
	28	50:1	0.35	87	213	70			0.12	0.18	0.25	0.37											
	23	60:1	0.28	80	180	67			0.12	0.18	0.25												
	20	70:1	N/A																				
	18	80:1	0.19	64	143	59			0.12	0.18													
14	100:1	0.15	59	132	55			0.12	0.18														
BWQ 63	186	7.5:1	3.80	178	435	94						0.55	0.75	1.1	1.5								
	140	10:1	2.90	190	465	92						0.55	0.75	1.1	1.5								
	93	15:1	2.00	192	470	90						0.55	0.75	1.1	1.5								
	70	20:1	1.60	198	485	87						0.55	0.75	1.1	1.5								
	56	25:1	1.40	202	494	81						0.55	0.75	1.1	1.5								
	47	30:1	1.15	191	469	78						0.55	0.75	1.1									
	35	40:1	0.85	184	450	76				0.25	0.37	0.55	0.75										
	28	50:1	0.65	164	402	71				0.25	0.37	0.55	0.75										
	23	60:1	0.50	145	326	68				0.25	0.37	0.55											
	20	70:1	N/A																				
	18	80:1	0.38	134	301	62				0.25	0.37												
14	100:1	0.29	118	264	57				0.25														

SELECCIÓN / SELECTION

Type	n2	Ratio :1	Max kW	M2 nM	Max M2 nM	Eff %	Motor Frame Size (kW)														
							80	80	90	90	100	100	112	132	132	160	160	160			
BWQ 75	186	7.5:1	5.20	243	596	94			1.1	1.5	2.2	3.0	4.0								
	140	10:1	3.70	242	593	92			1.1	1.5	2.2	3.0	4.0								
	93	15:1	2.50	240	588	90			1.1	1.5	2.2	3.0									
	70	20:1	2.10	260	636	87	0.55	0.75	1.1	1.5											
	56	25:1	1.80	259	635	81	0.55	0.75	1.1	1.5											
	47	30:1	1.50	250	611	78	0.55	0.75	1.1	1.5											
	35	40:1	1.20	259	635	76	0.55	0.75	1.1	1.5											
	28	50:1	0.90	227	556	71	0.55	0.75													
	23	60:1	0.80	232	522	68	0.55	0.75													
	20	70:1	N/A																		
	18	80:1	0.60		212	476	62	0.55													
	14	100:1	0.50		203	456	57	0.55													
	BWQ 90	186	7.5:1	9.00	416	1020	93			1.1	1.5	2.2	3.0	4.0							
		140	10:1	6.20	397	972	90			1.1	1.5	2.2	3.0	4.0							
93		15:1	4.40	418	1023	89			1.1	1.5	2.2	3.0	4.0								
70		20:1	3.50	438	1073	88			1.1	1.5	2.2	3.0	4.0								
56		25:1	3.10	479	1174	87			1.1	1.5	2.2	3.0									
47		30:1	2.50	421	1032	79			1.1	1.5	2.2	3.0									
35		40:1	2.00	444	1087	78	0.55	0.75	1.1	1.5											
28		50:1	1.60	438	1073	77	0.55	0.75	1.1	1.5											
23		60:1	1.20	389	875	76	0.55	0.75	1.1												
20		70:1	N/A																		
18		80:1	0.85		295	663	61	0.55	0.75												
14		100:1	0.70		299	672	60	0.55													
BWQ 110		186	7.5:1	13.4	627	1535	94					2.2	3.0	4.0	5.5	7.5					
		140	10:1	9.50	628	1538	93					2.2	3.0	4.0	5.5	7.5					
	93	15:1	6.80	660	1616	91					2.2	3.0	4.0	5.5	7.5						
	70	20:1	5.40	676	1655	88					2.2	3.0	4.0	5.5							
	56	25:1	4.80	699	1713	82			1.1	1.5	2.2	3.0	4.0								
	47	30:1	3.65	623	1525	80			1.1	1.5	2.2	3.0	4.0								
	35	40:1	2.80	629	1540	79			1.1	1.5	2.2	3.0									
	28	50:1	2.40	665	1630	78			1.1	1.5	2.2	3.0									
	23	60:1	2.05	664	1495	76			1.1	1.5	2.2										
	20	70:1	N/A																		
	18	80:1	1.50		563	1267	66			1.1	1.5										
	14	100:1	1.20		520	1171	61			1.1											
	BWQ 130	186	7.5:1	15.0	673	1640	94							5.5	7.5						
		140	10:1	12.5	792	1939	93							5.5	7.5						
93		15:1	9.5	887	2170	91							5.5	7.5							
70		20:1	7.2	874	2140	89							5.5	7.5							
56		25:1	6.1	863	2110	83					2.2	3.0	4.0	5.5	7.5						
47		30:1	5.9	959	2330	80					2.2	3.0	4.0	5.5							
35		40:1	4.5	970	2330	79					2.2	3.0	4.0	5.5							
28		50:1	3.5	931	2280	78					2.2	3.0	4.0								
23		60:1	2.9	915	2060	76					2.2	3.0									
20		70:1	N/A																		
18		80:1	2.1		724	1630	65				1.5	2.2									
14		100:1	1.6		654	1470	60				1.5										
BWQ 150		186	7,5	25,5	1190	2904	94										11	15	18		
		140	10	19,5	1230	3001	93										11	15	18		
	93	15	14,3	1278	3118	91										11	15				
	70	20	11	1280	3123	88										11	15				
	56	25	8,2	1190	2904	82								5,5	7,5						
	47	30	7,1	1190	2904	80								5,5	7,5						
	35	40	7,2	1548	3777	79								5,5	7,5						
	28	50	5,5	1410	3440	78								5,5							
	23	60	4,4	1272	2862	76								5,5							
	20	70	N/A																		
	18	80	3,0		1139	2563	66						3	4							
	14	100	2,4		996	2241	61					2,2	3								

DIMENSIONES BWQ25 / BWQ25 DIMENSIONS

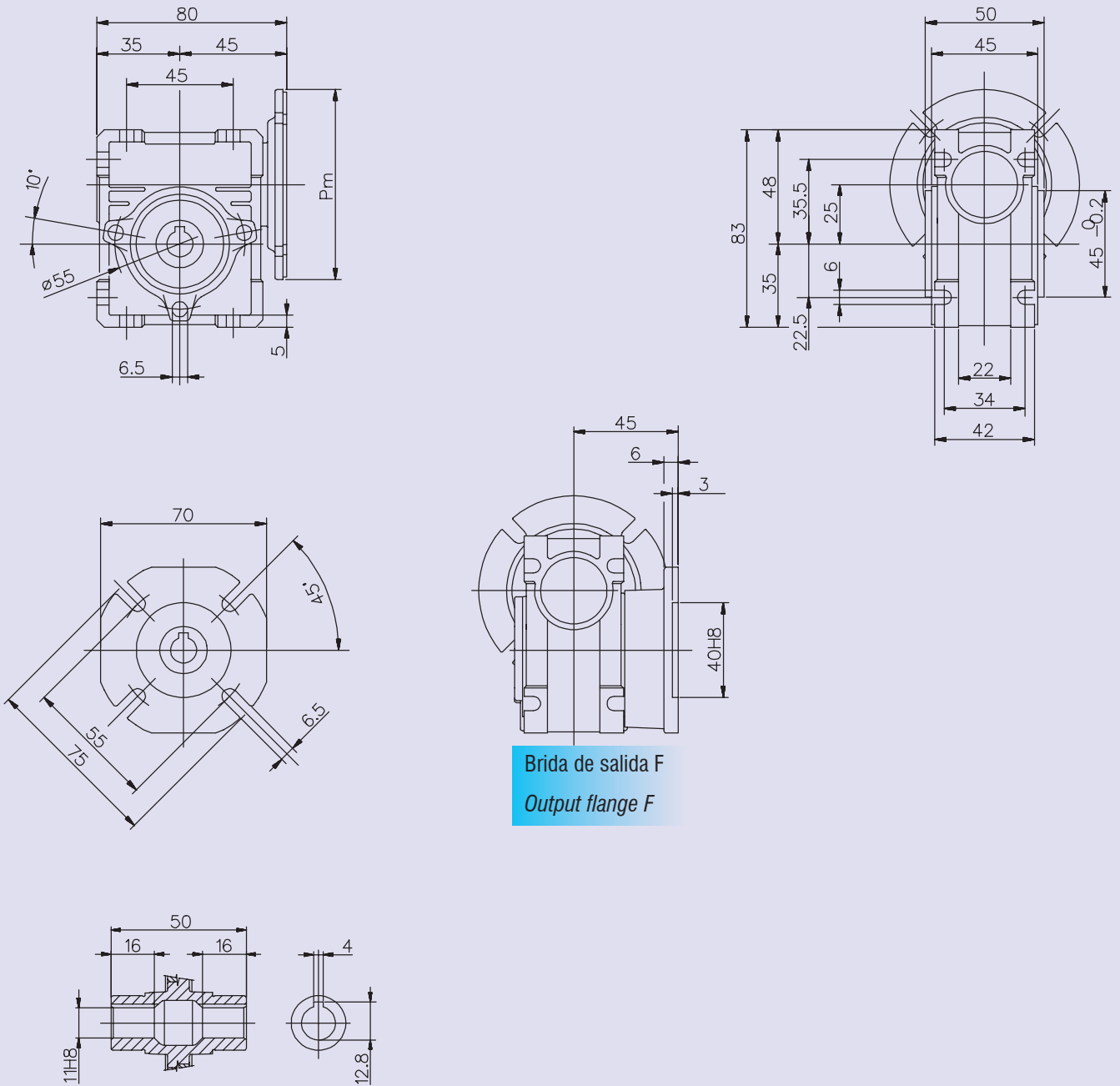

Brida de salida F
Output flange F

· Peso sin motor	0,7 kg
· Cantidad de aceite	0,02 L.
· Weight without motor	0.7 kg
· Quantity of oil	0.02 L.

DIMENSIONES BWQ30 / BWQ30 DIMENSIONS

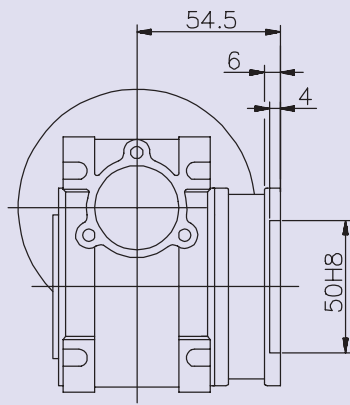
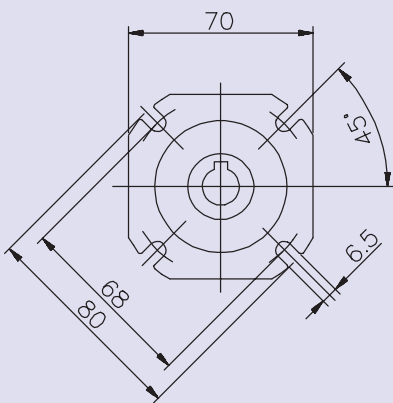
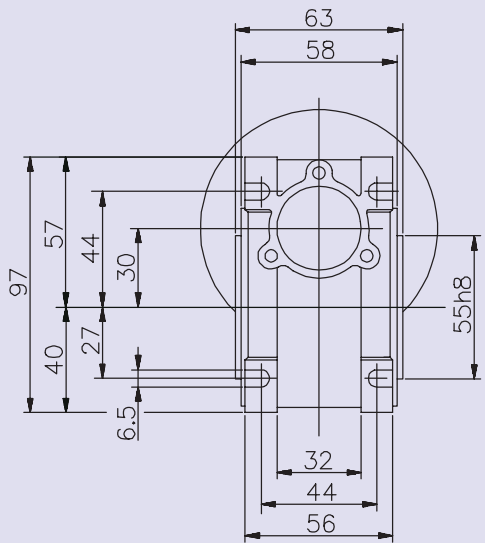
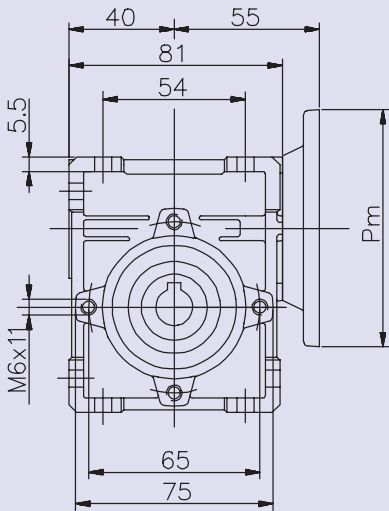

Brida de salida F
Output flange F

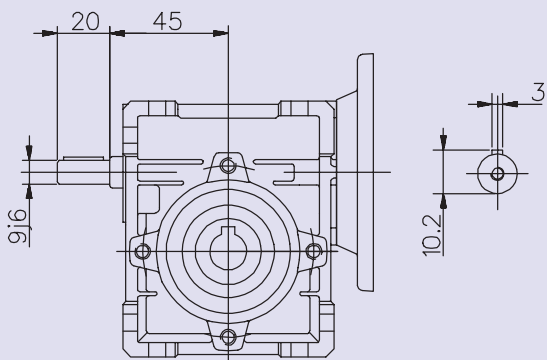

BWQ30W

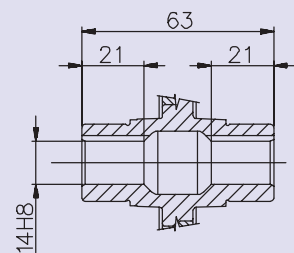
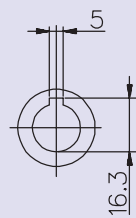

· Peso sin motor	0,7 kg
· Cantidad de aceite	0,04 L.
· Weight without motor	0.7 kg
· Quantity of oil	0.04 L.

DIMENSIONES BWQ40 / BWQ40 DIMENSIONS

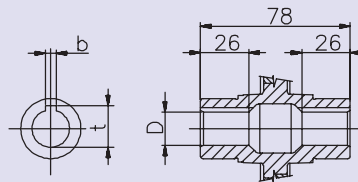
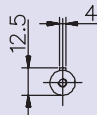
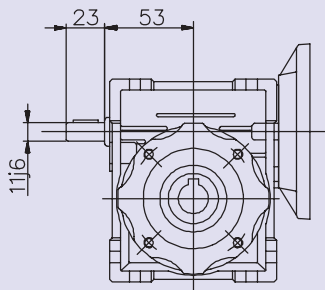
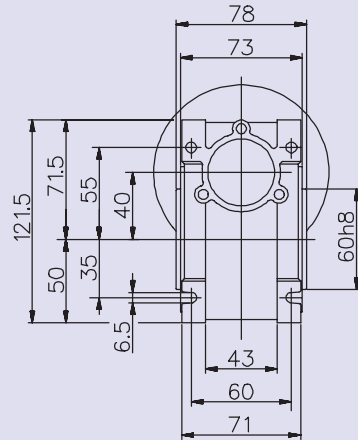
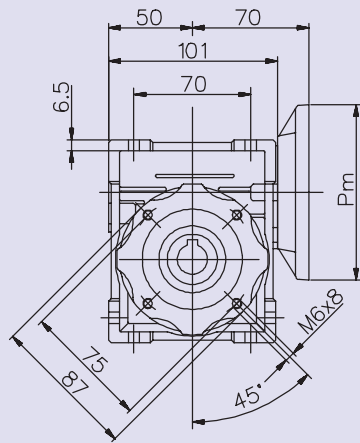

BWQ40W

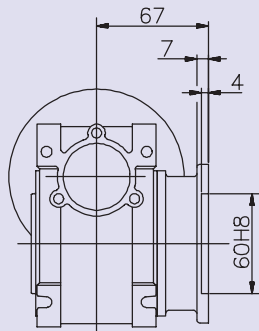
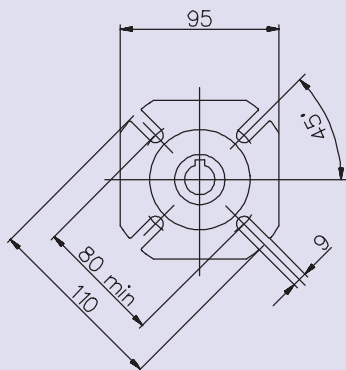

Brida de salida F
Output flange F

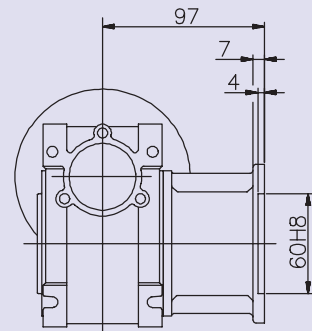

Brida de salida FL
Output flange FL

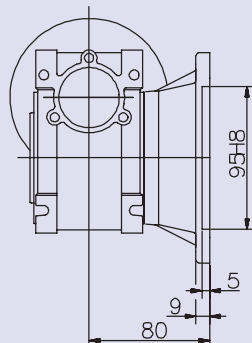
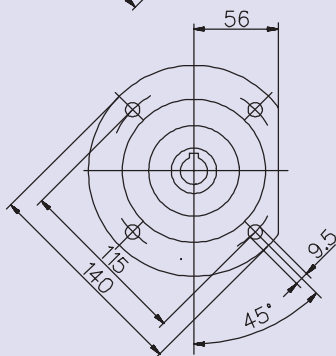

Brida de salida FC
Output flange FC

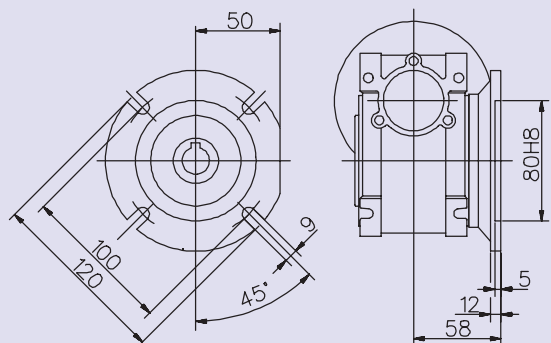

Brida de salida FD
Output flange FD

- Peso sin motor 2,3 kg
- Cantidad de aceite 0,08 L.

- Weight without motor 2.3 kg
- Quantity of oil 0.08 L.

Salida / Output		
DH8	b	t
18	6	20,8

DIMENSIONES BWQ50 / BWQ50 DIMENSIONS

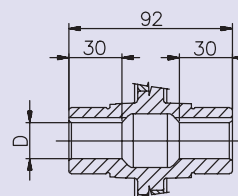
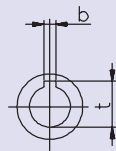
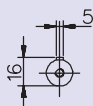
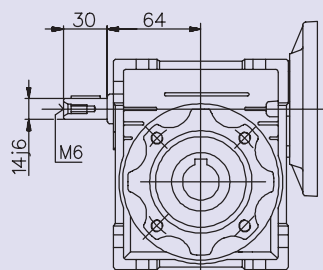
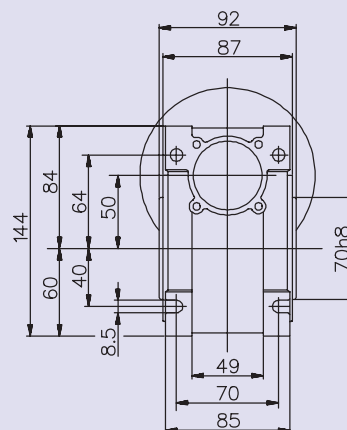
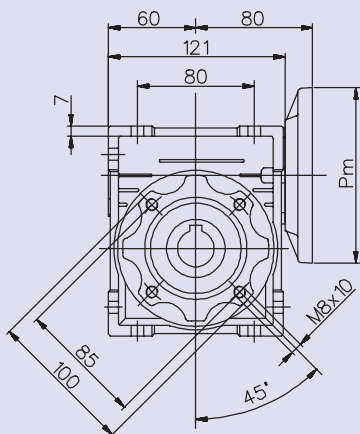

BWQ50W

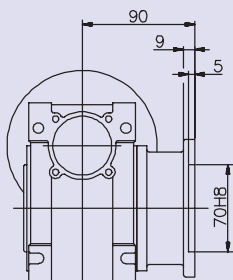
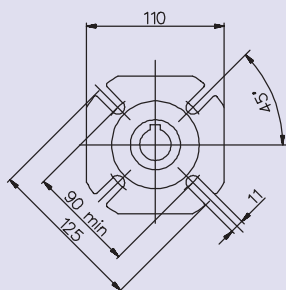

**Brida de salida F
Output flange F**

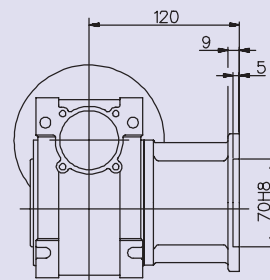

**Brida de salida FL
Output flange FL**

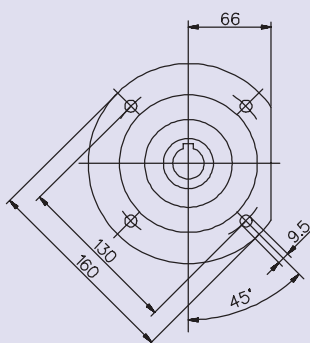

**Brida de salida FC
Output flange FC**

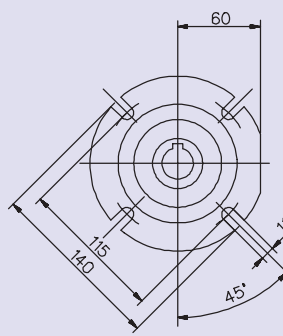
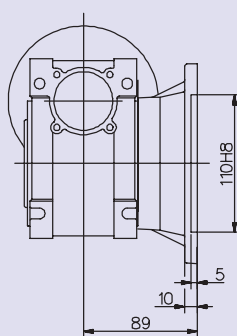

**Brida de salida FD
Output flange FD**

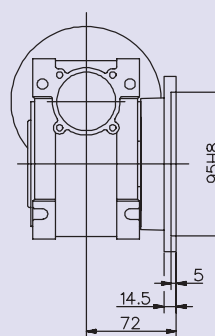

- Peso sin motor 3,5 kg
- Cantidad de aceite 0,15 L.
- Weight without motor 3.5 kg
- Quantity of oil 0.15 L.

Salida / Output		
DH8	b	t
25	8	28,3

DIMENSIONES BWQ63 / BWQ63 DIMENSIONS

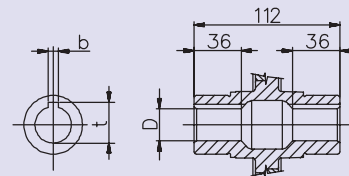
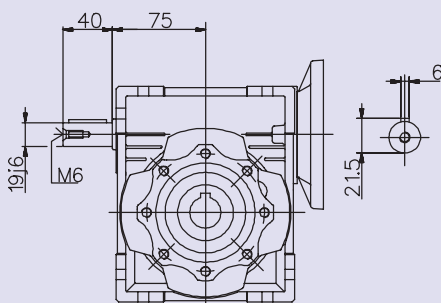
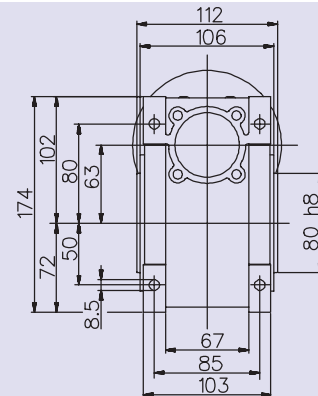
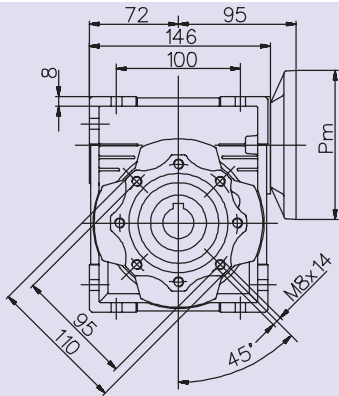

BWQ63W

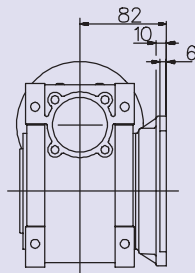
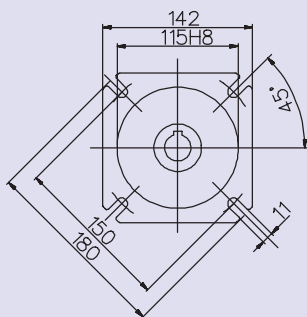

Brida de salida F
Output flange F

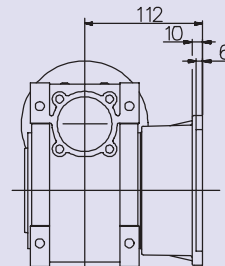

Brida de salida FL
Output flange FL

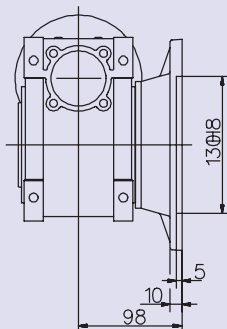
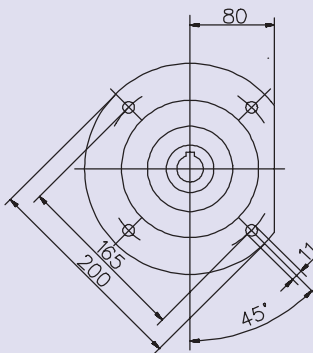

Brida de salida FC
Output flange FC

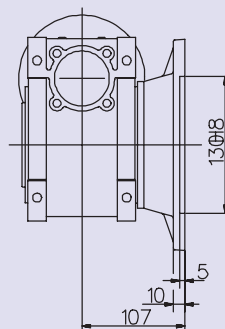

Brida de salida FD
Output flange FD

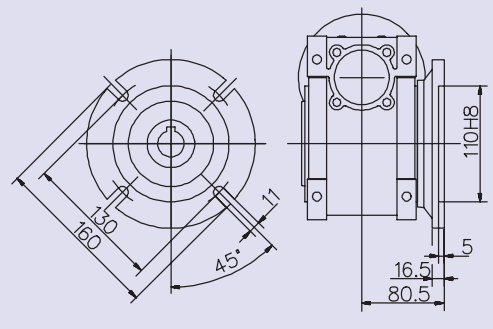

Brida de salida FE
Output flange FE

- Peso sin motor 6,2 kg
- Cantidad de aceite 0,3 L.

- Weight without motor 6.2 kg
- Quantity of oil 0.3 L.

Salida / Output		
DH8	b	t
25	8	28,3

DIMENSIONES BWQ75 / BWQ75 DIMENSIONS

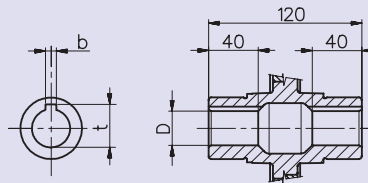
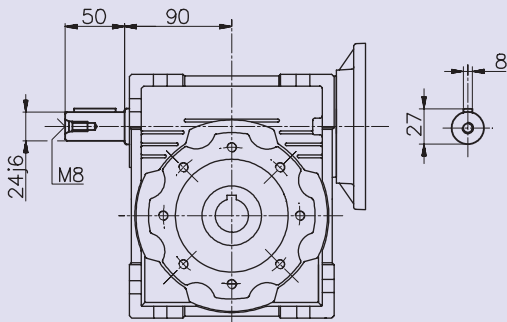
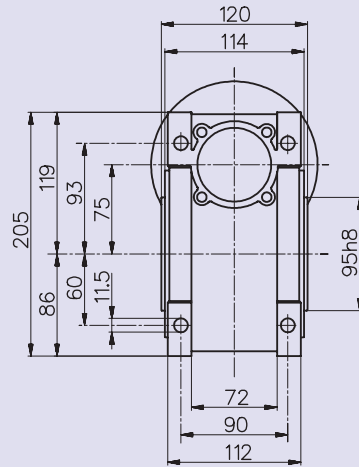
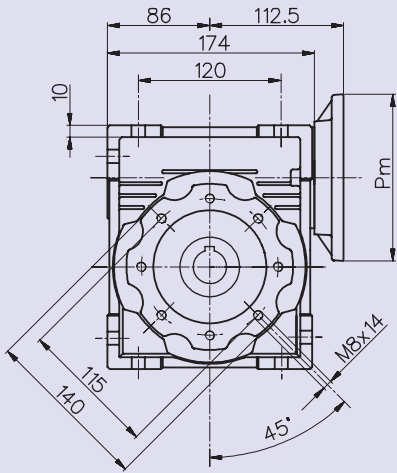

BWQ75W

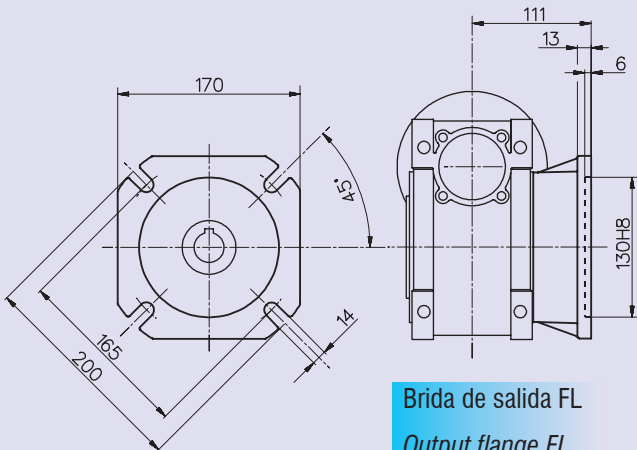

Brida de salida FL
Output flange FL

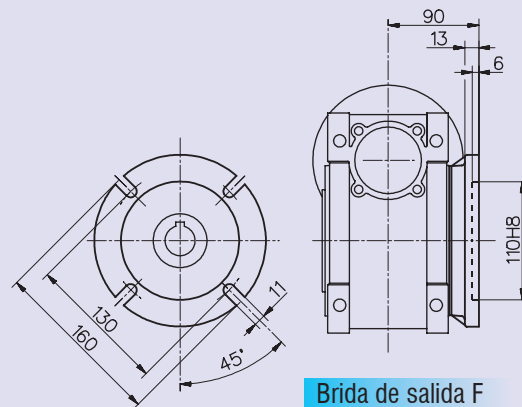

Brida de salida F
Output flange F

- Peso sin motor 9 kg
- Cantidad de aceite 0,55 L.

- Weight without motor 9 kg
- Quantity of oil 0.55 L.

Salida / Output		
DH8	b	t
28	8	31,3

DIMENSIONES BWQ90 / BWQ90 DIMENSIONS

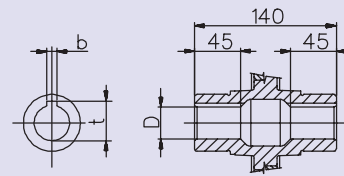
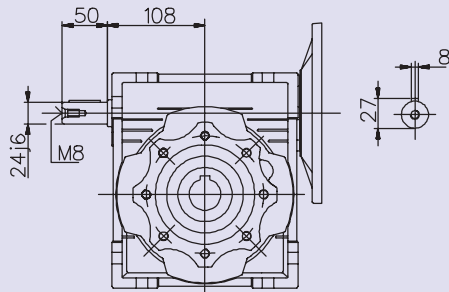
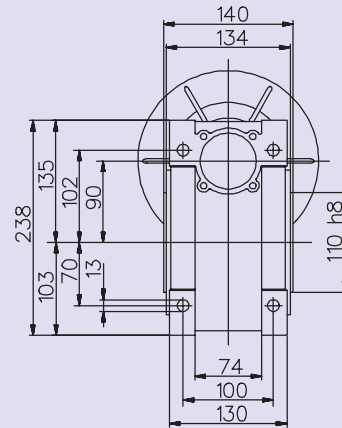
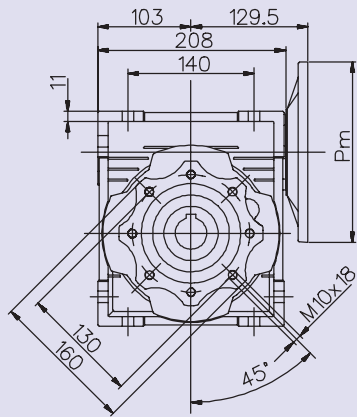

BWQ90W

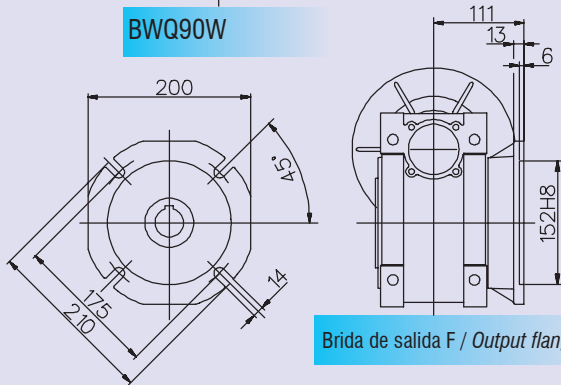

Brida de salida F / Output flange F

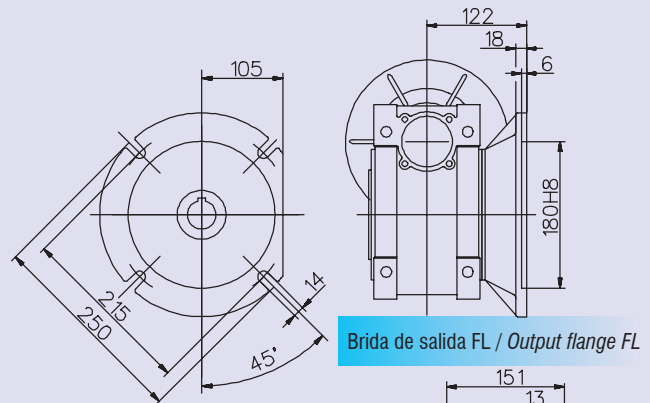

Brida de salida FL / Output flange FL

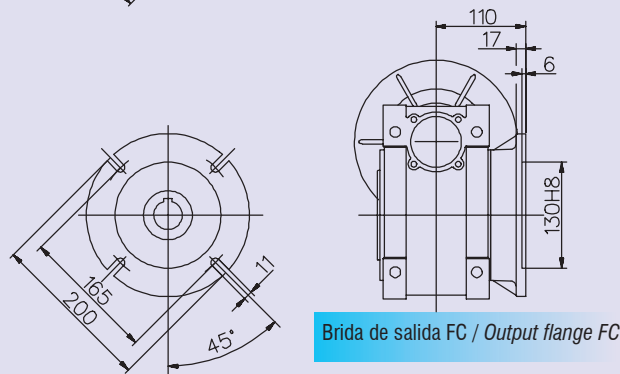

Brida de salida FC / Output flange FC

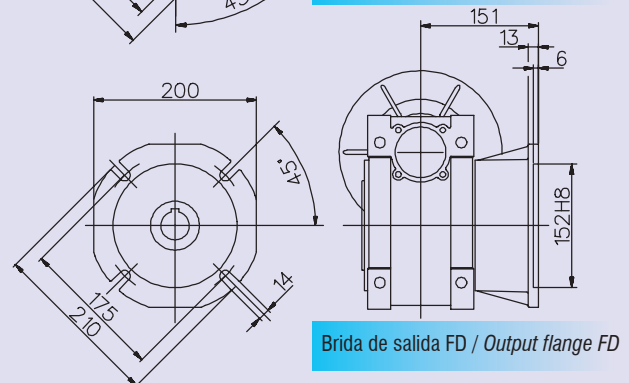

Brida de salida FD / Output flange FD

- Peso sin motor 13 kg
- Cantidad de aceite 1 L.

- Weight without motor 13 kg
- Quantity of oil 1 L.

Salida / Output		
DH8	b	t
35	10	38,3

DIMENSIONES BWQ110 / BWQ110 DIMENSIONS

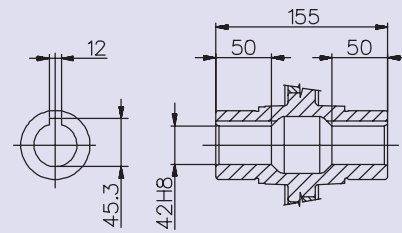
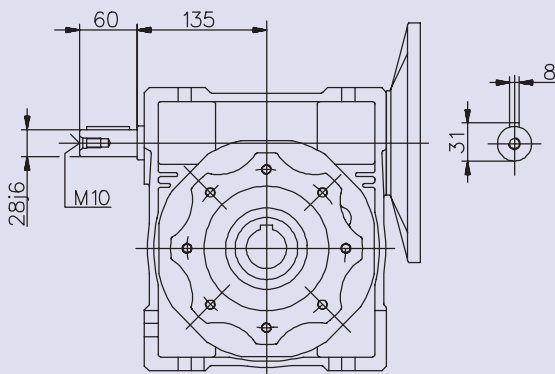
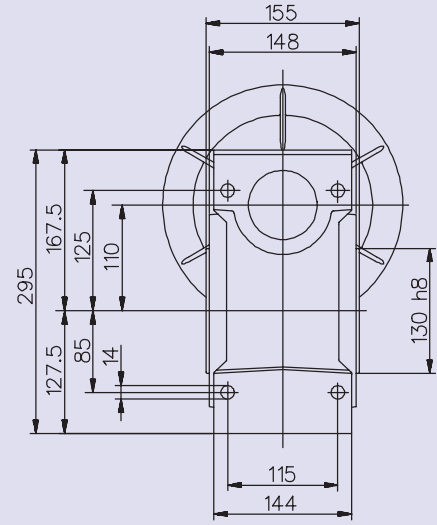
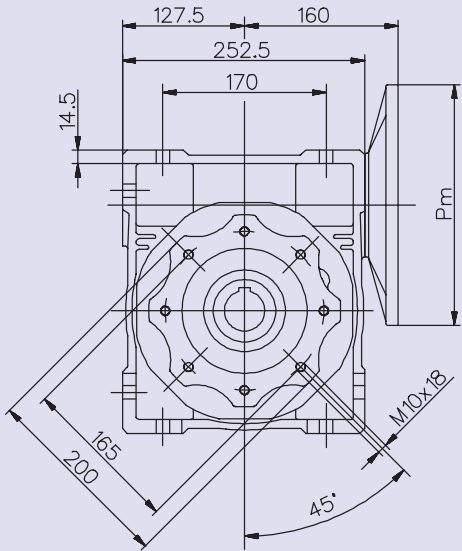

BWQ110W

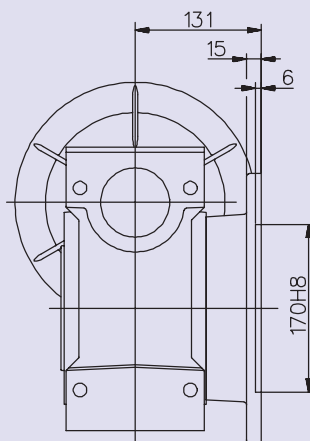
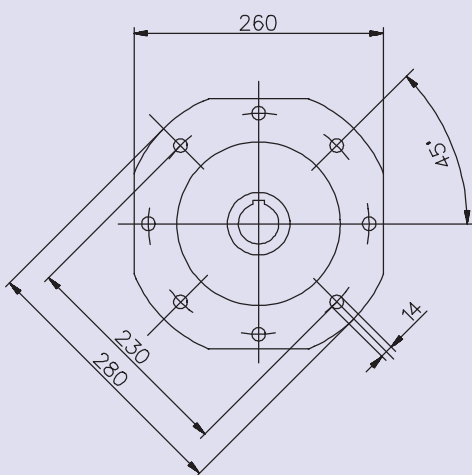

Brida de salida F
Output flange F

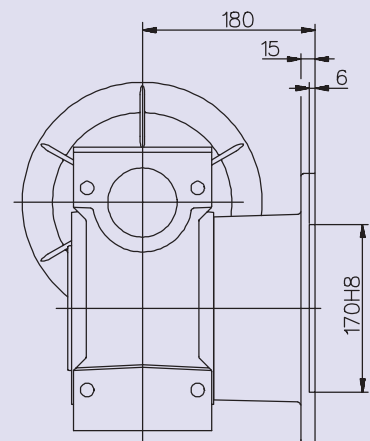

Brida de salida FL
Output flange FL

· Peso sin motor	35 kg	· Weight without motor	35 kg
· Cantidad de aceite	B3= 3 L.	· Quantity of oil	B3= 3 L.
	B8= 2,2 L.		B8= 2,2 L.
	B6-B7= 2,5 L.		B6-B7= 2,5 L.
	V5-V6= 3 L.		V5-V6= 3 L.

DIMENSIONES BWQ130 / BWQ130 DIMENSIONS

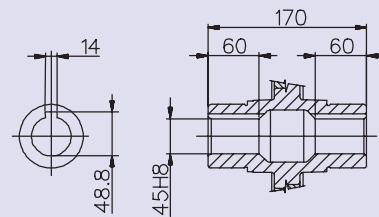
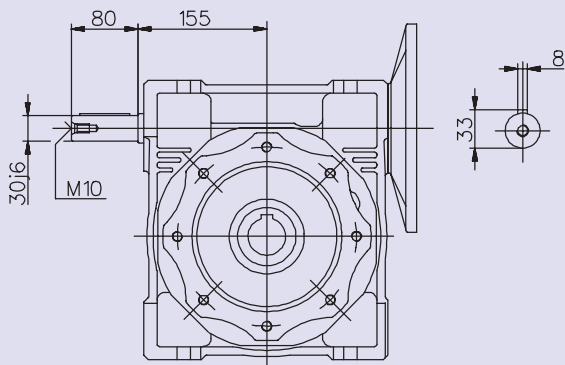
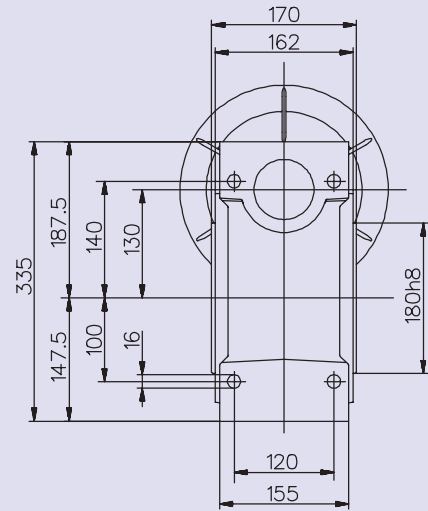
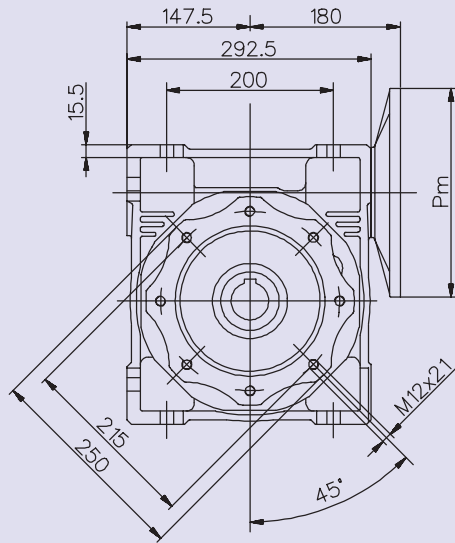

BWQ130W

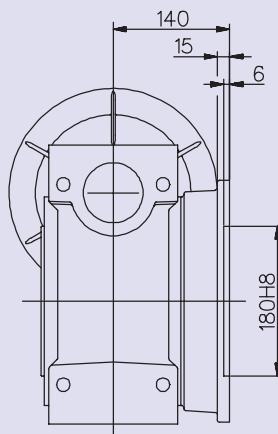
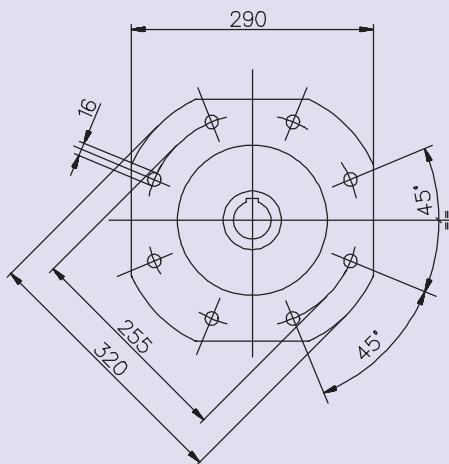

Brida de salida F
Output flange F

· Peso sin motor	B3=	48 kg	· Weight without motor	B3=	48 kg
· Cantidad de aceite	B8=	4,5 L.	· Quantity of oil	B8=	4,5 L.
	B6-B7=	3,3 L.		B6-B7=	3,3 L.
	V5-V6=	3,5 L.		V5-V6=	3,5 L.
		4,5 L.			4,5 L.

DIMENSIONES BWQ150 / BWQ150 DIMENSIONS

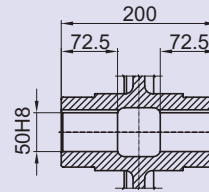
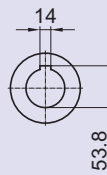
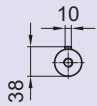
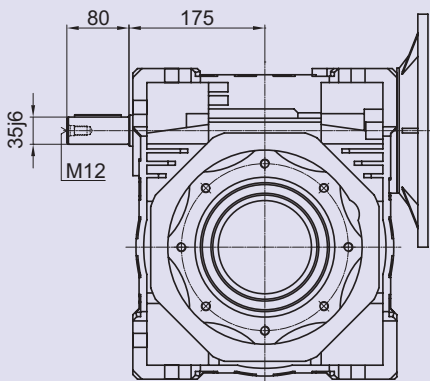
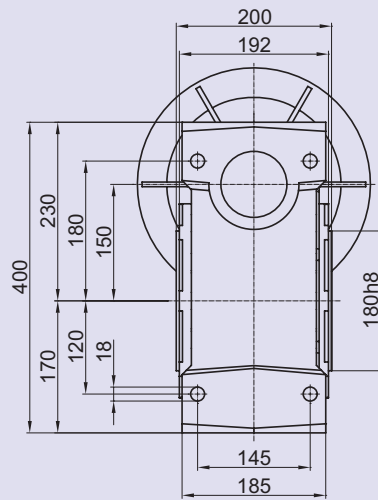
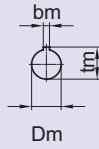
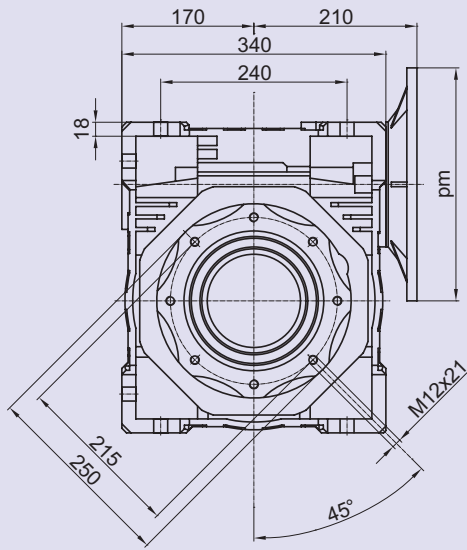

BWQ150W

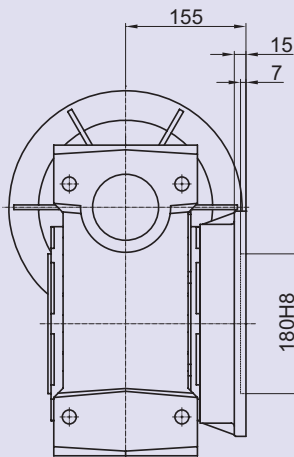
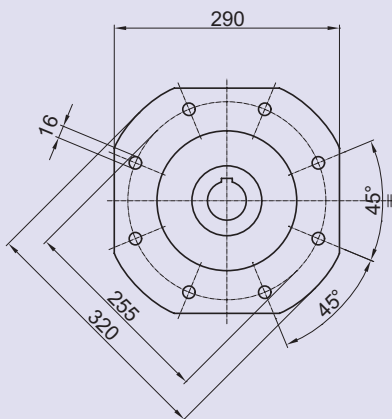

Brida de salida F
Output flange F

· Peso sin motor	84 Kgs	· Weight without motor	84 Kgs
· Cantidad de aceite	B3= 7 L.	· Quantity of oil	B3= 7 L.
	B8= 5,1 L.		B8= 5,1 L.
	B6-B7= 5,4 L.		B6-B7= 5,4 L.
	V5= 7 L.		V5= 7 L.
	V6= 5,1 L.		V6= 5,1 L.

DIMENSIONES EJE LIBRE DE ENTRADA / FREE INPUT SHAFT DIMENSIONS

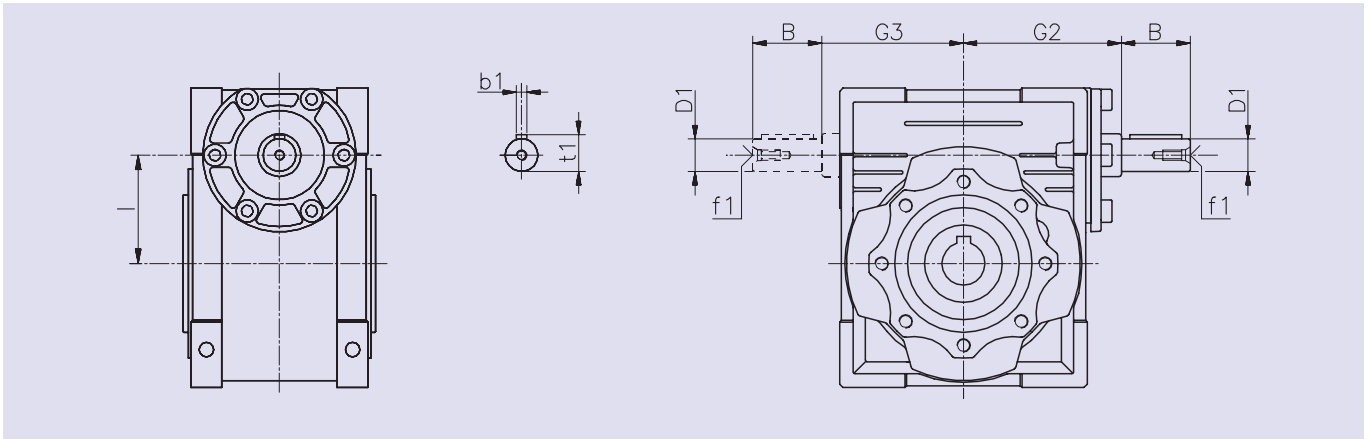

BWQ	30	40	50	63	75	90	110	130	150
B	20	23	30	40	50	50	60	80	80
D1	9 j6	11 j6	14 j6	19 j6	24 j6	24 j6	28 j6	30 j6	35 j6
G2	51	60	74	90	105	125	142	162	195
G3	45	53	64	75	90	108	135	155	175
l	30	40	50	63	75	90	110	130	150
b1	3	4	5	6	8	8	8	8	10
f1	-	-	M6	M6	M8	M8	M10	M10	M12
t1	10,2	12,5	16	21,5	27	27	3		38

DIMENSIONES EJE LIBRE DE ENTRADA EN REDUCTOR COMBINADO BWQ + BWQ FREE INPUT SHAFT DIMENSIONS IN COMBINATION GEARBOX BWQ + BWQ

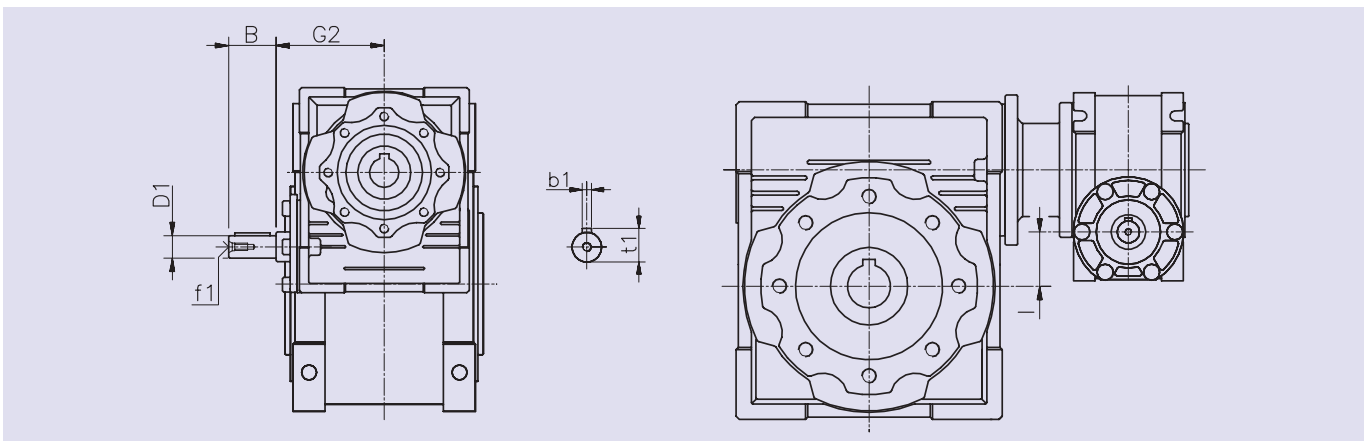

BWQ	30 - 40	30 - 50	30 - 63	40 - 75	40 - 90	50 - 110	63 - 130	63 - 150
B	20	20	20	23	23	30	40	40
D1	9 j6	9 j6	9 j6	11 j6	11 j6	14 j6	19 j6	19 j6
G2	51	51	51	60	60	74	90	90
l	10	20	33	35	50	60	67	87
b1	3	3	3	4	4	5	6	6
f1	-	-	-	-	-	M6	M6	M6
t1	10,2	10,2	10,2	12,5	12,5	16	21,5	21,5

EJES DE SALIDA SIMPLES Y DOBLES / SINGLE AND DOUBLE OUTPUT SHAFT

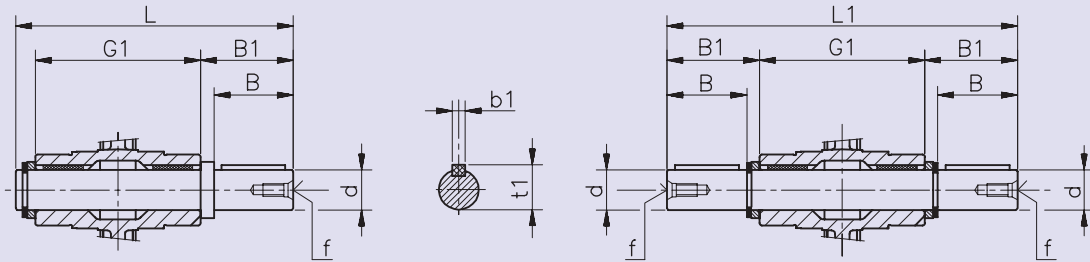

	d	B	B1	G1	L	L1	f	b1	t1
025	11 g6	23	25,5	50	81	101	-	4	12,5
030	14 h6	30	32	63	102	128	M6	-	16
040	18 h6	40	43	78	128	164	M6	6	20,5
050	25 h6	50	53,5	92	153	199	M10	8	28
063	25 h6	50	53,5	112	173	219	M10	8	28
075	28 h6	60	63,5	120	192	247	M10	8	31
090	35 h6	80	84,5	140	234	309	M12	10	38
110	42 h6	80	84,5	155	249	324	M16	12	45
130	45 h6	80	85	170	265	340	M16	14	48,5
150	50h6	82	87	200	297	374	M16	14	53,5

BRAZO DE REACCIÓN / TORQUE ARM

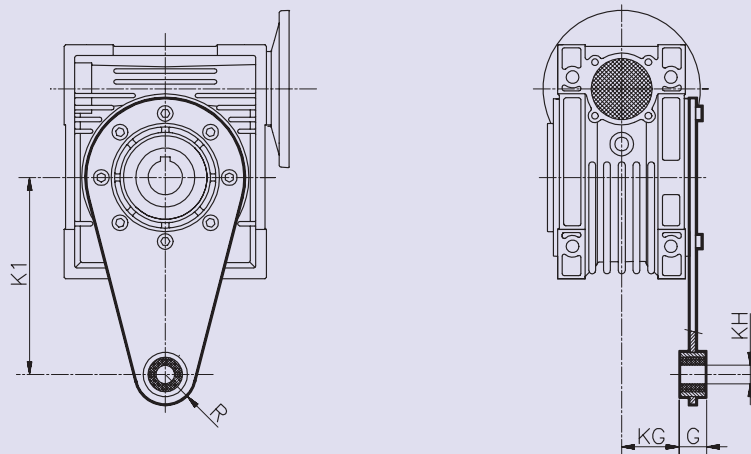

	K1	G	KG	KH	R
025	70	14	17,5	8	15
030	85	14	24	8	15
040	100	14	31,5	10	18
050	100	14	38,5	10	18
063	150	14	49	10	18
075	200	25	47,5	20	30
090	200	25	57,5	20	30
110	250	30	62	25	35
130	250	30	69	25	35
150	250	30	84	25	35

Reductor y motorreductor
tipo sinfín/corona combinado

*Combination worm
gear units*

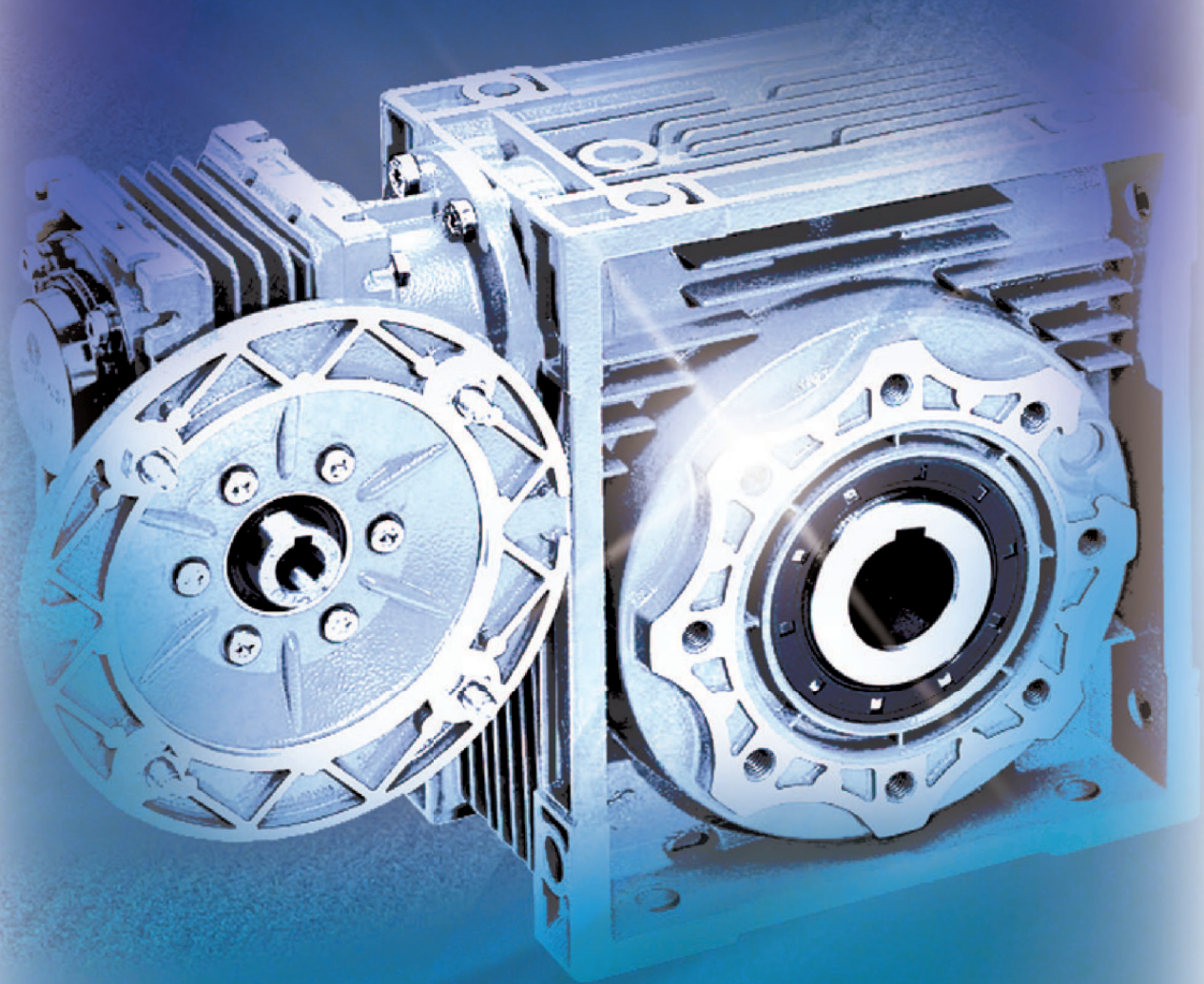

BWQ + BWQ

SELECCIÓN COMBINADO / PARAMETER TABLE

n1=1400 rpm

TIPO	i	n2	kw1	M2 Nm	i1	i2
BWQ 30/40	300	4,7	0,08	73	10	30
	400	3,5	0,06	65	10	40
	500	2,8	0,04	61	20	25
	600	2,3	0,04	73	20	30
	750	1,9	0,04	73	25	30
	900	1,6	0,03	73	30	30
	1200	1,2	0,02	65	30	40
	1500	0,9	0,02	73	50	30
	1800	0,8	0,02	73	60	30
	2400	0,58	0,01	65	60	40
	3200	0,5	0,01	65	80	40
	4000	0,35	0,01	33	50	80
5000	0,28	0,01	29	50	100	

TIPO	i	n2	kw1	M2 Nm	i1	i2
BWQ 40/90	300	4,7	0,56	610	7,5	40
	400	3,5	0,43	610	10	40
	500	2,8	0,34	560	10	50
	600	2,3	0,3	610	15	40
	750	1,9	0,23	560	15	50
	900	1,6	0,19	505	15	60
	1200	1,2	0,17	610	30	40
	1500	0,90	0,14	560	30	50
	1800	0,78	0,11	505	30	60
	2400	0,58	0,11	610	60	40
	3000	0,5	0,08	560	60	50
	4000	0,35	0,08	460	50	80
5000	0,28	0,06	410	50	100	

TIPO	i	n2	kw1	M2 Nm	i1	i2
BWQ 30/50	300	4,7	0,15	145	10	30
	400	3,5	0,1	124	10	40
	500	2,8	0,09	120	10	50
	600	2,3	0,08	145	20	30
	750	1,9	0,07	145	25	30
	900	1,6	0,06	145	30	30
	1200	1,2	0,04	124	30	40
	1500	0,90	0,04	145	50	30
	1800	0,78	0,04	145	60	30
	2400	0,58	0,03	124	60	40
	3000	0,5	0,02	120	60	50
	4000	0,35	0,02	82	50	80
4800	0,28	0,02	82	60	80	

TIPO	i	n2	kw1	M2 Nm	i1	i2
BWQ 50/110	300	4,7	0,95	1100	10	30
	400	3,5	0,69	1030	10	40
	500	2,8	0,56	1000	10	50
	600	2,3	0,48	1030	15	40
	750	1,9	0,43	1100	25	30
	900	1,6	0,38	1100	30	30
	1200	1,2	0,27	1030	30	40
	1500	0,90	0,28	1100	50	30
	1800	0,78	0,23	1100	60	30
	2400	0,58	0,17	1030	60	40
	3000	0,5	0,14	1000	60	50
	4000	0,35	0,12	780	50	80
5000	0,28	0,09	710	50	100	

TIPO	i	n2	kw1	M2 Nm	i1	i2
BWQ 30/63	300	4,7	0,24	230	7,5	40
	400	3,5	0,19	230	10	40
	500	2,8	0,15	216	10	50
	600	2,3	0,13	230	15	40
	750	1,9	0,11	216	15	50
	900	1,6	0,09	198	15	60
	1200	1,2	0,08	230	30	40
	1500	0,90	0,06	216	30	50
	1800	0,78	0,05	198	30	60
	2400	0,58	0,05	230	60	40
	3000	0,5	0,04	216	60	50
	4000	0,35	0,03	172	50	80
5000	0,28	0,02	150	50	100	

TIPO	i	n2	kw1	M2 Nm	i1	i2
BWQ 63/130	300	4,7	1,48	1760	10	30
	400	3,5	1,09	1650	10	40
	500	2,8	0,86	1550	10	50
	600	2,3	0,76	1650	15	40
	750	1,9	0,66	1760	25	30
	900	1,6	0,58	1760	30	30
	1200	1,2	0,43	1650	30	40
	1500	0,90	0,39	1760	50	30
	1800	0,78	0,35	1760	60	30
	2400	0,58	0,25	1650	60	40
	3000	0,5	0,2	1550	60	50
	4000	0,35	0,15	1220	50	80
5000	0,28	0,11	1100	50	100	

TIPO	i	n2	kw1	M2 Nm	i1	i2
BWQ 40/75	300	4,7	0,36	390	10	30
	400	3,5	0,27	360	10	40
	500	2,8	0,21	320	10	50
	600	2,3	0,19	390	20	30
	750	1,9	0,16	390	25	30
	900	1,6	0,14	390	30	30
	1200	1,2	0,11	360	30	40
	1500	0,90	0,1	390	50	30
	1800	0,78	0,09	390	60	30
	2400	0,58	0,07	360	60	40
	3000	0,5	0,05	320	60	50
	4000	0,35	0,04	250	50	80
5000	0,28	0,03	230	50	100	

TIPO	i	n2	kw1	M2 Nm	i1	i2
BWQ 63/150	300	4,7	1,9	2340	15	20
	400	3,5	1,8	2670	10	40
	500	2,8	1,4	2330	10	50
	600	2,3	1,3	2670	15	40
	750	1,9	1	2330	15	50
	900	1,6	0,7	2100	30	30
	1200	1,2	0,7	2670	30	40
	1800	0,8	0,4	2100	60	30
	2400	0,6	0,5	2670	60	40
	3000	0,5	0,3	2330	60	50
	4000	0,4	0,2	1880	80	50
	5000	0,3	0,2	1650	100	50

DIMENSIONES BWQ+BWQ COMBINADO / DIMENSIONS BWQ+BWQ COMBINATION

BWQ30 + 25

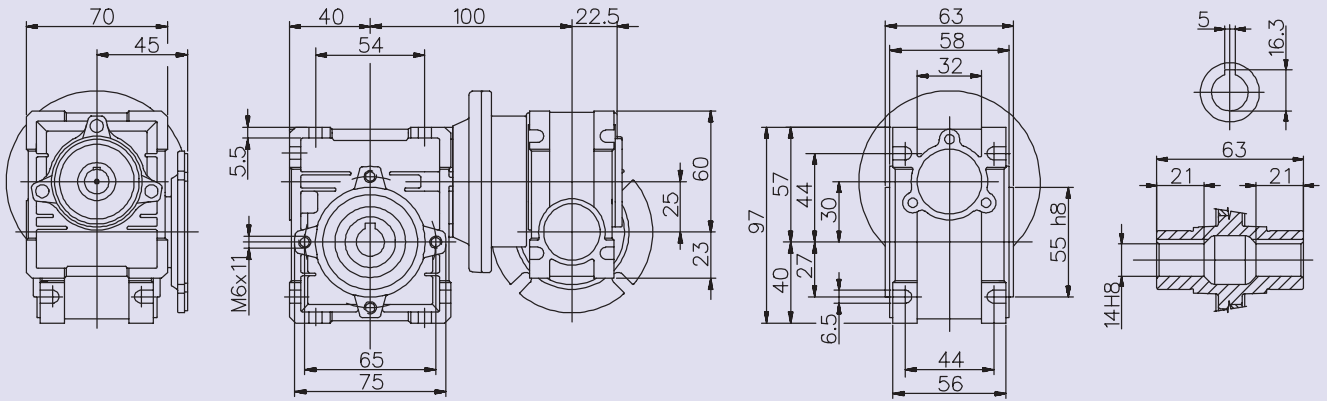

BWQ40 + 30

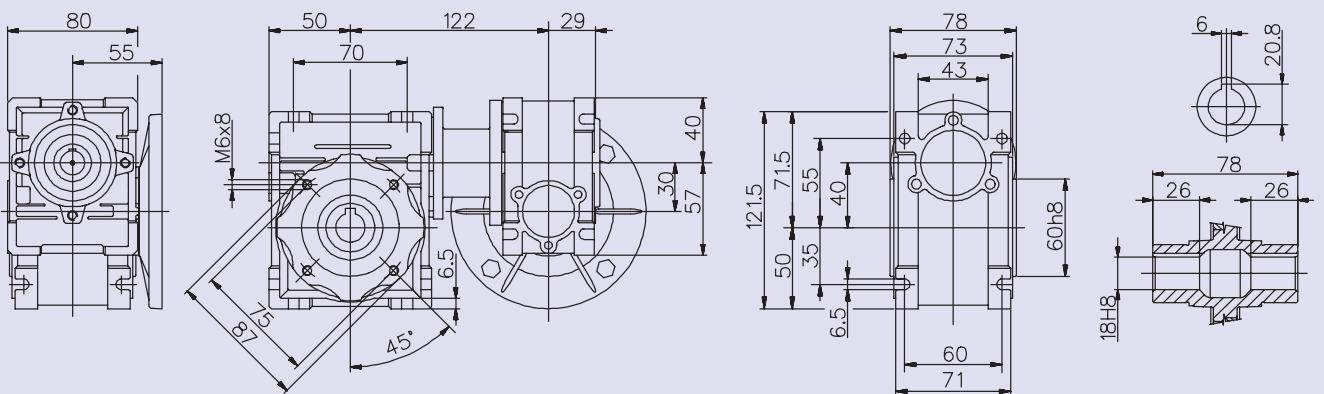

BWQ50 + 30

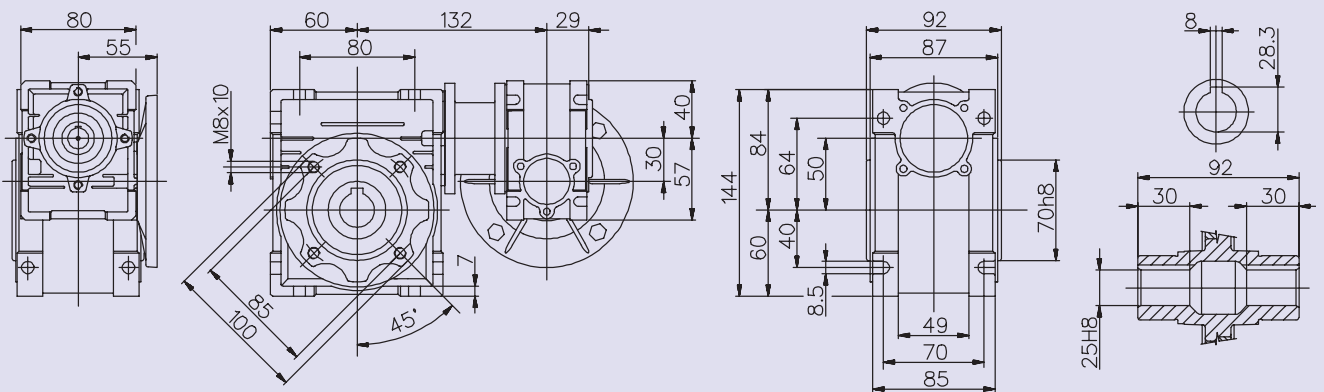

DIMENSIONES BWQ+BWQ COMBINADO / DIMENSIONS BWQ+BWQ COMBINATION

BWQ63 + 50

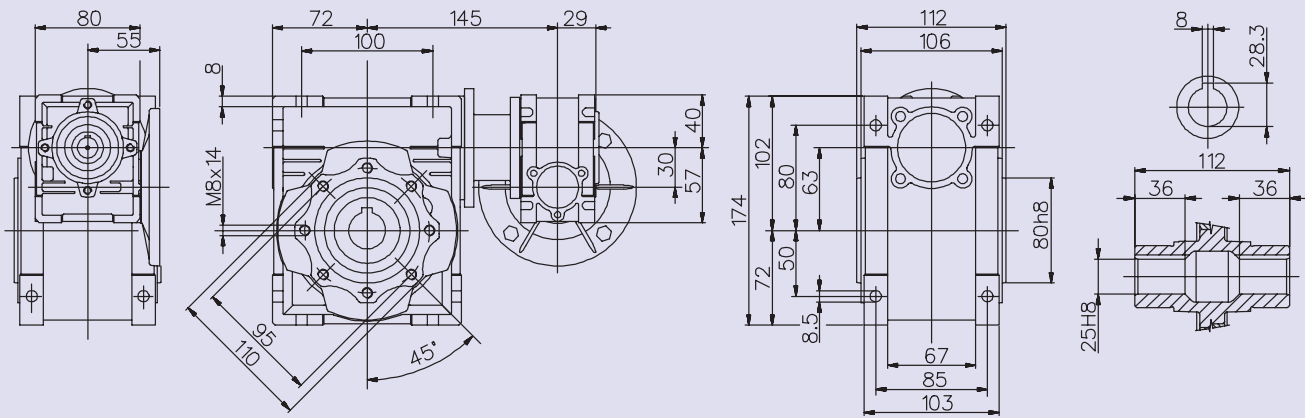

BWQ75 + 40

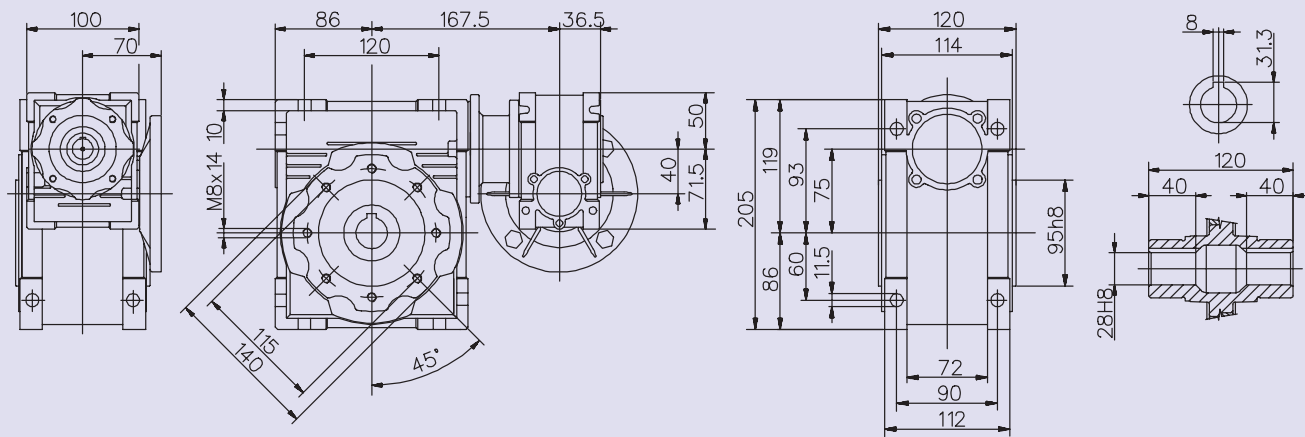

BWQ90 + 40

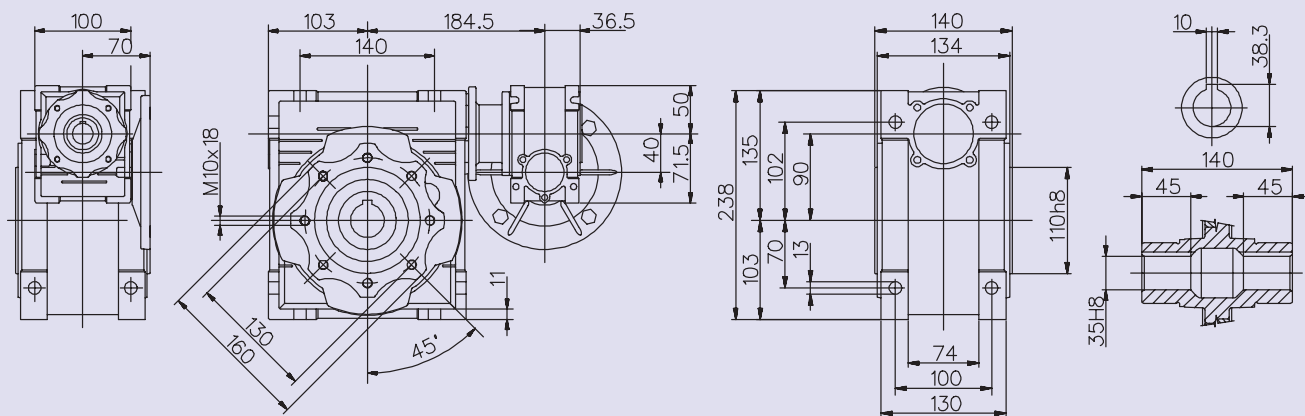

DIMENSIONES BWQ+BWQ COMBINADO / DIMENSIONS BWQ+BWQ COMBINATION

BWQ110 + 50

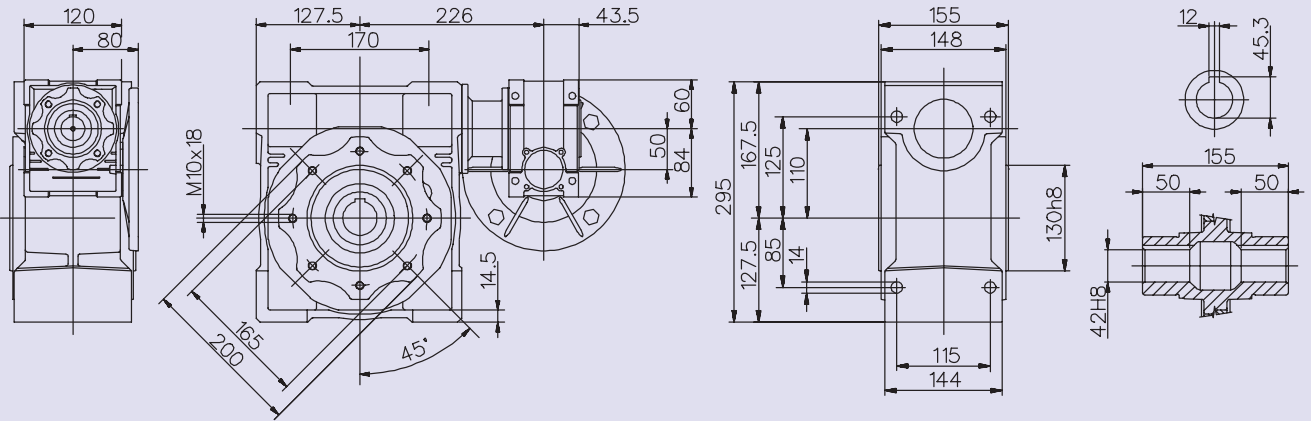

BWQ130 + 63

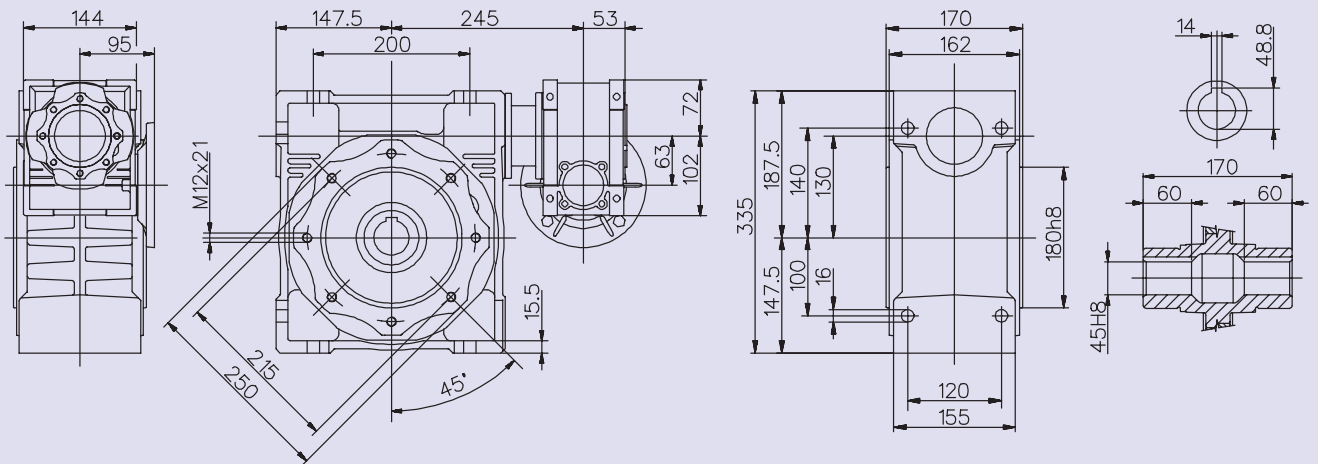

BWQ150 + 63

